



TIME LAPSE VIDEO CASSETTE RECORDER INSTALLATION AND OPERATION MANUAL

MODEL

HS-7168E(B)

HS-7168EM(B)

HS-7168E(A)

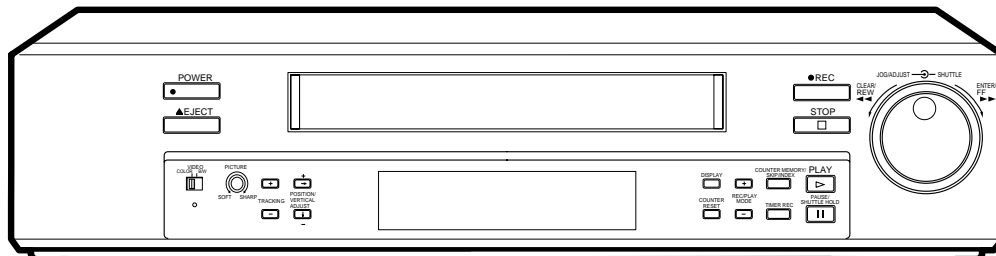

ONLY VIDEO CASSETTE TAPES WITH THE **VHS** MARK MAY BE USED WITH THIS MODEL.

THIS INSTRUCTION MANUAL IS IMPORTANT TO YOU.
PLEASE READ IT BEFORE USING YOUR VIDEO CASSETTE RECORDER.

CAUTION AND CARE

CONDENSATION IS THE ENEMY OF VIDEO RECORDERS

■ WHAT IS CONDENSATION?

1. When a very cold drink is poured into a glass, the water droplets which form on the outer surface of the glass are an example of condensation.
2. If the VCR is exposed to a rapid increase in temperature (such as warming a cold room or after transporting it from a cold location to a warm one) condensation may form on the tape transport mechanism inside the VCR. To prevent damage to the VCR or tapes, plug the VCR into the mains outlet and turn the power on for about 2 hours. Do not use the VCR for playback or record during this time.

■ CONDENSATION IS LIKELY TO OCCUR WHEN:

1. The VCR is moved inside from outdoors, or from a cold room to a warm one.
2. A cold room is heated quickly.
3. Humidity is high.

NOTE:

- Avoid using the VCR where cold air (e.g., from an air conditioner) will blow directly on it.
- Never place anything containing water on top of the VCR, e.g., vases, cups, etc.

HEAVY OBJECTS SHOULD NEVER BE PLACED ON THE VCR (E.G., TV)

UNPLUGGING THE MAINS LEAD

Whenever unplugging the mains leads, be sure to switch off the mains outlet first. Then unplug the lead by gripping the plug (not the lead) and carefully remove the plug from the mains outlet.

NEVER TOUCH OR INSERT ANY OBJECT INSIDE THE VCR

Touching the inside of the cabinet or inserting foreign objects of any kind not only creates a safety hazard but can also cause extensive damage.

PROTECT THE MAINS LEAD

Damage to the mains lead may cause fire or shock hazard.

UNPLUG THE MAINS LEAD DURING A LONG ABSENCE

During a long absence, turn off the power and switch off the mains outlet before unplugging the mains lead.

MAINTAIN GOOD VENTILATION

Do not obstruct the many ventilation holes on the VCR. For maximum ventilation, place the unit on a hard level surface only, and ensure it is not covered during use. Heavy objects should never be placed on the VCR.

WHEN NOT IN USE

When you finish operating the VCR always unload the cassette and turn OFF the VCR POWER.

CABINET CARE

Never use petroleum-based cleaners. Clean with a soft cloth moistened with soap and water and wipe dry. PVC cables or leads should not be left in contact with the cabinet surface for long periods.

INSTALLATION LOCATION

For optimum performance and reliability, install the VCR in a location that is:

1. Well ventilated, out of direct sunlight and away from direct heat.
2. A solid vibration-free surface.
3. Free from high humidity, excessive dust and away from magnetic fields.

NOTE:

- Never move the VCR without first removing the tape.

CARE OF VIDEO CASSETTE TAPES

- Avoid violent vibration or shock.
- Do not place near a strong magnetic field (e.g., a motor, transformer or magnet).
- Never place or store in direct sunlight.
- Avoid dusty places.
- Place the cassette in its case and store vertically.

WARNING: TO PREVENT FIRE OR SHOCK HAZARD, DO NOT EXPOSE THIS APPARATUS TO RAIN OR MOISTURE.

For HS-7168E(B) and HS-7168EM(B)

■ MAINS LEAD CONNECTION

The mains lead on this VCR is fitted with a non-rewireable mains plug, incorporating a 5A fuse. If you need to replace the fuse, use a 5A fuse approved by BSI or ASTA to BS 1362, ensuring you refit the fuse cover. If the mains plug is not suitable for the sockets in your home, and you require to remove the plug, remove the fuse, cut off the plug then dispose of the plug immediately, to avoid a possible electric shock hazard. To refit a new plug, follow these instructions; Green-and-yellow: Earth,
Blue: Neutral,
Brown: Live

As the colours in the mains lead of this VCR may not correspond with the coloured markings identifying the terminals in your plug, proceed as follows.

- The wire which is coloured green-and-yellow must be connected to the terminal in the plug which is marked by the letter E or by the safety earth symbol \perp or coloured green or green-and-yellow.
- The wire which is coloured blue must be connected to the terminal which is marked with the letter N or coloured black.
- The wire which is coloured brown must be connected to the terminal which is marked with the letter L or coloured red.

WARNING: THIS APPARATUS MUST BE EARTHED.

This Time Lapse Video Cassette Recorder complies with the requirements of the EC Directive 89/336/EEC, "EMC Directive" and 73/23/EEC, "Low Voltage Directive", as amended by Directive 93/68/EEC. The requirements for the susceptibility according to EN 50082-1 and the requirements for interference according to EN 55022 are observed for the operation on residential areas, business, light industrial premises and in small scale enterprises, inside as well as outside of the building. All places of operation are characterised by their connection to the public low voltage power supply system.

This unit is manufactured in accordance with EN60065.

CONTENTS

	Pages	Pages
FEATURES AND FUNCTIONS		
Front view	3	
Fluorescent display	4	
Rear view	5	
CONNECTING WITH OTHER EQUIPMENT	6	
SETTING THE MENUS	7, 8, 9, 10	
SETTING THE PRESENT TIME	11, 12	
LOADING AND UNLOADING THE CASSETTE TAPE	13	
MANUAL RECORDING	14, 15, 16	
Audio recording	14	
Repeat recording	15	
Series recording	15	
One shot/Interval recording	16	
Synchronous recording	16	
ADDITIONAL FEATURES		
Counter memory	17	
Tape counter	17	
Counter reset	17	
Memory back-up in case of power failure	17	
Recording after a power failure	17	
Power failure time display	17	
Elapsed time display		17
TIMER RECORDING		18, 19
ALARM RECORDING		20, 21, 22
Alarm recording connection		20
External time clock adjustment		20
Setting for alarm recording		21
Emergency recording		21
Alarm record time display		22
Locating the start of alarm recordings		22
PLAYBACK		23
Audio playback		23
SPECIAL EFFECTS PLAYBACK		24
ADJUSTMENT DURING PLAYBACK		
Tracking adjustment		25
Picture quality adjustment		25
Vertical adjustment		25
WARNING DISPLAY		26
BEFORE CALLING FOR SERVICE		27
CONTROL INPUT/OUTPUT SIGNALS AND CIRCUITS ..		28, 29
SPECIFICATIONS		30

FEATURES

Up to 168 hours of recording: an ideal video system for automated security and surveillance systems.

This time lapse VCR is designed especially for industrial, educational and security recording. In addition to ordinary 3-hour and 6-hour recording modes, it has time lapse modes that allow recording of 18, 24, 48, 72, 96, 120 or 168 hours. Also, the recording time can be extended up to 54,000 hours (for E-180 tape) if you choose one-shot recording with 3 minutes interval time. Frame-by-frame playback and high-speed playback of longer recordings are also available. This adds up to a powerful surveillance system for banks, buildings, traffic and parking lots, as well as a convenient scientific tool for observation of plant growth, animal behaviour and other time-intensive processes.

Audio recording

When recording in 3H, 6H, L(linear)18H, or L24H mode, audio is played back only during their respective modes.

Resolution and image quality

This VCR has a high quality circuit, which makes it possible to attain more than 330 lines in B/W mode, and more than 240 lines in colour mode(SP mode).

High density recording - H•D<LP>

High Density recording records 2x more fields than Normal Density (SP). It reduces the time interval between pictures, providing more pictures for smoother time lapse recording.

Tape remaining indicator

A bar indicator shows how much tape is left and/or that the tape has approximately three minutes (in 3H mode) left.

Automatic head cleaning

For continuous smooth operation, the VCR automatically removes foreign matter from the heads when a cassette is inserted.

Easy setting using a monitor

The on-screen menus simplify setting-up procedures. These menus can be selected even without the input of a video signal.

Easy cueing with alarm recording

Index signals are added automatically at the beginning of "alarm recording" for easy cueing. You can confirm the Alarm starting time in the playback video on the monitor with the Alarm list using the Maintenance menu.

Time date search system

Input the day and time you want to view and the VCR will search and display it automatically.

External time clock adjustment

The on-screen time clock can be reset to the nearest hour by applying a signal to the RST(RESET) IN terminal at the rear of the VCR.

Record check

Correct recording can be confirmed by pressing the PLAY button during recording.

Automatic azimuth head selection

This VCR can automatically select playback heads for normal VHS compatible Time Lapse recordings, or older Time Lapse recordings made using two Same Azimuth video heads. Same Azimuth Time Lapse recordings use VHS cassettes but cannot be played normally by VHS compatible VCRs.

Full lock mode

Locking prevents the VCR from being operated by an unauthorised third party.

Special playback features

These include still images, speed search, reverse playback, frame-by-frame viewing in both directions, slow motion and high speed viewing.

JOG dial/SHUTTLE ring

Use to search for the desired image. You can adjust the playback speed with the SHUTTLE ring and search for an image frame by frame with the JOG dial.

Recording options

This versatile system offers a variety of recording options, including daily and weekly timer recording, repeat and alarm recording.

Protection against power failures

Recording data including date, time and timer set-up, are stored in backup memory, so the system can resume recording after a power failure. The time of the failure is displayed on the monitor.

Digital <ELAPSED TIME> display

The Elapsed Time of recording and playback is stored in a non-volatile memory IC. The elapsed time display should be used as a guide as to when periodic maintenance should be carried out.

Tape use counter

Displays how many times you have repeatedly recorded on a tape. This is helpful for deciding when it is necessary to replace a tape.

Daylight saving time setting

Daylight saving time setting is available. The clock can be put forward by one hour by setting the menu.

FEATURES AND FUNCTIONS

FRONT VIEW

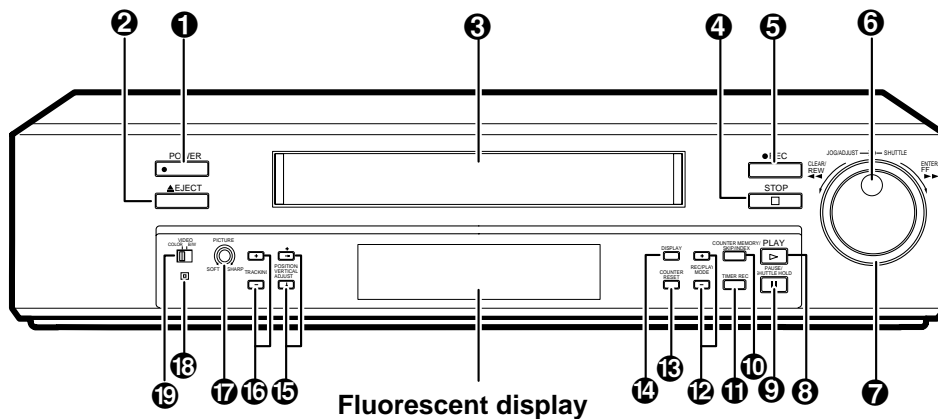

1 POWER button (Press for on; press again for off)
The POWER indicator illuminates when the VCR is switched on.

2 EJECT button
Press to remove the cassette.

3 Cassette loading slot
Cassette tape is inserted in this slot for loading.

4 STOP button
Press to discontinue all tape related functions.

5 REC (RECORD) button
Press to begin recording.

6 JOG dial
Use to forward the tape frame-by-frame and to set the menus.

7 SHUTTLE ring
Use to adjust the playback speed or to set the menus. Turn this ring to the right to forward a tape or to forward search. Turn this ring to the left to rewind a tape or to reverse search. Also, use to reset the alarm list, power loss list and timer recording and to initialize the menu settings.

8 PLAY button
Press to playback a previously recorded tape.

9 PAUSE/SHUTTLE HOLD button
When pressed during recording, tape movement stops temporarily. Press again to continue the recording. When pressed during playback, tape movement stops and a still field is displayed. Press again to restore normal playback. Pressing and holding this button after turning the SHUTTLE ring allows continuous high speed playback even if the SHUTTLE ring is released.

10 COUNTER MEMORY/SKIP/INDEX button
Use to switch between COUNTER MEMORY(P.17), SKIP SEARCH or INDEX SEARCH(P.22).

11 TIMER REC button
This button is pressed when a timer recording is to be made.

12 REC/PLAY MODE buttons
Set to 3H, L24H, 48H - 168H or 0H mode to select recording speed in SP mode. Set to 3H, L24H, 24H, 48H - 168H or 0H mode to select playback speed during playback recorded in SP mode. Set to 6H, L18H, 48H - 168H or 0H mode to select recording speed in LP mode. Set to 6H, L18H, 48H - 168H or 0H mode to select playback speed during playback recorded in LP mode.

13 COUNTER RESET button
Press to reset the counter to "00000".

14 DISPLAY button
Press to display the MAIN MENU.
Press again to show the present time display.

15 POSITION/VERTICAL ADJUST buttons

- When (+) button is pressed, the day and present time display will move to the right. When the (-) button is pressed, the day and present time will move down the screen. Cannot be adjusted if a warning is displayed.
- Press these buttons to adjust for vertical vibrations when in still mode or during fast playback. Refer to pages 6 and 25 for more details.

16 TRACKING buttons (+/-)
Press these buttons if noise is present during playback, reverse playback or slow playback.

17 PICTURE control
The picture quality can be adjusted between soft and sharp.

18 LOCK button
When pressed with a ball-point pen or a pencil, the unit will be locked into the current mode and the operation buttons will not operate. Release the lock by pressing the lock button again.

19 VIDEO switch
Use to select color or black and white recording and playback.

FLUORESCENT DISPLAY

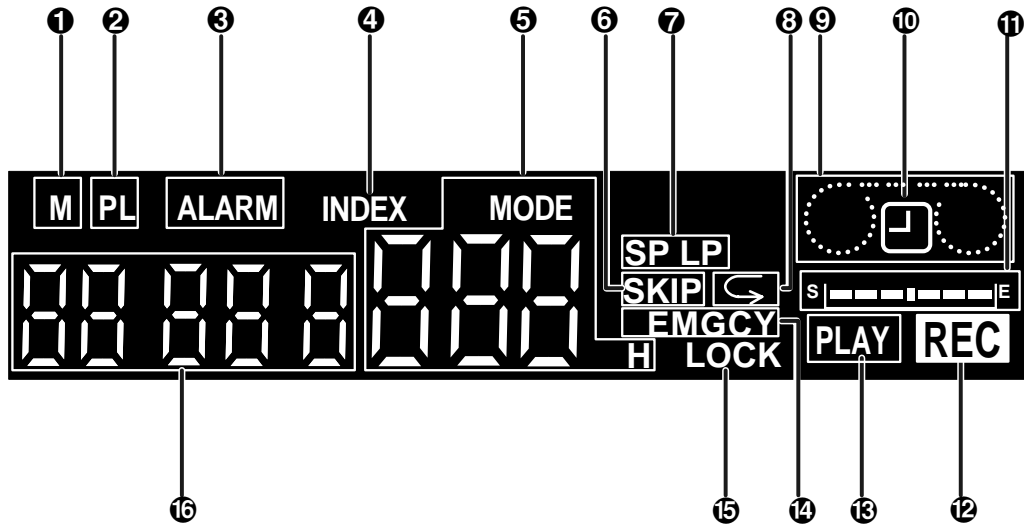

- ❶ M (COUNTER MEMORY) indicator
Illuminates during rewind for counter memory mode.
 - ❷ PL (POWER LOSS) indicator
Illuminates when there is a power failure during recording.
 - ❸ ALARM indicator
Flashes during alarm recording and stays on when the alarm recording is finished.
 - ❹ INDEX indicator
Flashes during recording of date/hour index signal at the change of the hour, and during recording of the alarm index signal. Lights during index search.
 - ❺ MODE display
Displays the selected recording or playback mode. During index search, displays the index number. It will also indicate the playback head selection, "SH" or "AH", 3 seconds after the playback starts or if the playback mode is changed. In the "FIRST TIME SET UP" menu, if the "PB HEAD" selection is set to "L/L" or "R/R" then "SH" will illuminate. If set to "AUTO", then "AH" will illuminate.
- NOTE:**
- "SH" or "AH" lights during playback in SP mode ONLY.
- ❻ SKIP indicator
Illuminates during skip search.
 - ❼ Record mode indicator
LP illuminates to indicate recording in LP mode or playing back a tape recorded in LP mode. SP illuminates to indicate recording in SP mode or playing back a tape recorded in SP mode.
 - ❽ Repeat indicator
Illuminates when "TAPE END" in the "FIRST TIME SET UP" menu is set to "REPEAT" or "ALARM•PROT".
 - ❾ Cassette status indicator
Illuminates when tape is inserted. The light advances, stops or flashes corresponding to the movement of the tape.
 - ❿ Timer recording indicator
Illuminates when the TIMER REC button is set to ON.
 - ⓫ Tape remaining indicator
Indicates the approximate tape position. S=Start, E=End.
 - ⓬ REC indicator
Illuminates during recording.
 - ⓭ PLAY indicator
Illuminates during playback.
 - ⓮ EMGCY (EMERGENCY REC) indicator
Illuminates when "EMERGENCY REC" of the "RECORDING SET UP" menu is set to "ON".
 - ⓯ LOCK indicator
Lights when the Lock mode is set.
 - ⓰ COUNTER display
Indicates the relative position on the tape.

FEATURES AND FUNCTIONS

REAR VIEW

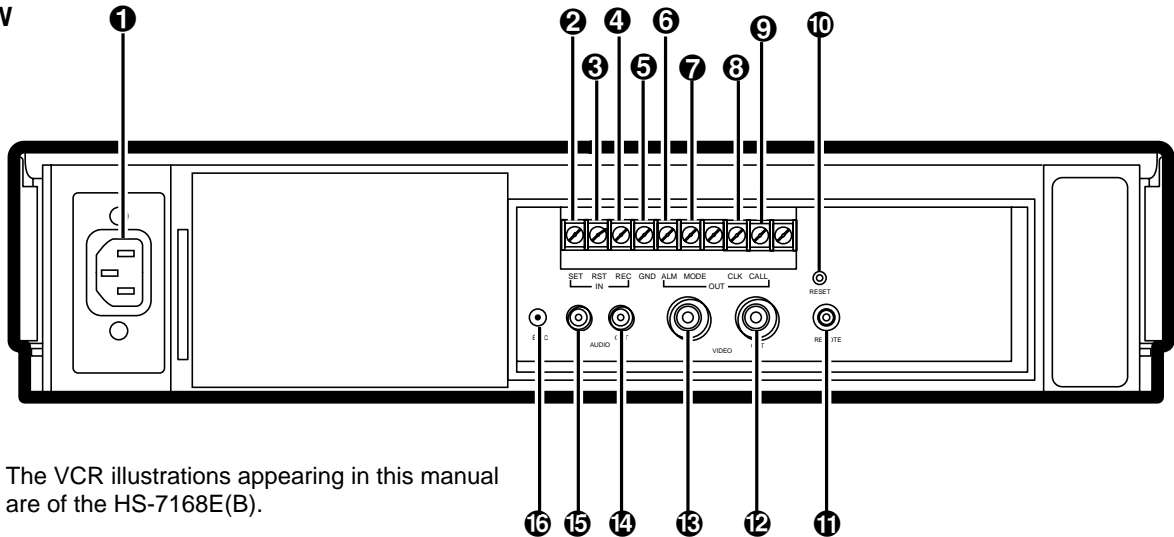

The VCR illustrations appearing in this manual are of the HS-7168E(B).

NOTE:

- Ensure the power cord is not plugged into the mains outlet before connecting to any rear terminals.

❶ AC power socket

This socket connects to the power cord. Insert the cord firmly.

❷ SET IN terminal

Input terminal for alarm recording. The alarm sensor is connected here.

❸ RST (RESET) IN terminal

Input terminal to stop alarm recording when "ALARM RECORDING DURATION" of the "RECORDING SET UP" menu is set to "MAN1". The alarm reset switch is connected here. This terminal can also be used to set the on-screen clock when set to any mode other than "MAN1".

❹ REC IN terminal

Input terminal to start/stop recording. Also, use this terminal for series recording (P.15) or synchronous recording (P.16).

❺ GND (GROUND) terminal

When a lead connected to other terminals requires a ground, connect the ground lead here.

❻ ALM (ALARM) OUT terminal

Output terminal to indicate alarm recording to an external alarm.

❼ MODE OUT terminal

Output terminal to indicate the VCR's mode of operation. Selected by setting "MODE OUT" on the "REAR TERMINAL" menu.

❽ CLK (CLOCK) OUT terminal

Output terminal to control an external camera switcher.

❾ CALL OUT terminal

Output terminal to indicate when tape has finished recording or if there has been a problem during recording.

❿ RESET button

When pressed, the present time, alarm recording list, power loss list and the number of tape use will be erased. While the button is pressed, the power is cut off from the VCR. If there is a tape in the VCR and the button is released, the power indicator will light and the tape will fast forward for a few seconds. The VCR will then switch off.

⓫ REMOTE jack

Remote control is possible by connecting the optional remote control unit (R-7100) here. Refer to page 29.

⓬ VIDEO OUT connector

Output connector for video signal (BNC connector). If the power switch is turned OFF, the signal from the VIDEO IN connector is looped out to this connector.

⓭ VIDEO IN connector

Input connector for video signal (BNC connector).

⓮ AUDIO OUT connector

Audio output connector (RCA pin).

⓯ AUDIO IN connector

Audio input connector (RCA pin).

⓰ MIC IN jack

Input jack for a microphone with 600 ohms impedance.

CONNECTING WITH OTHER EQUIPMENT

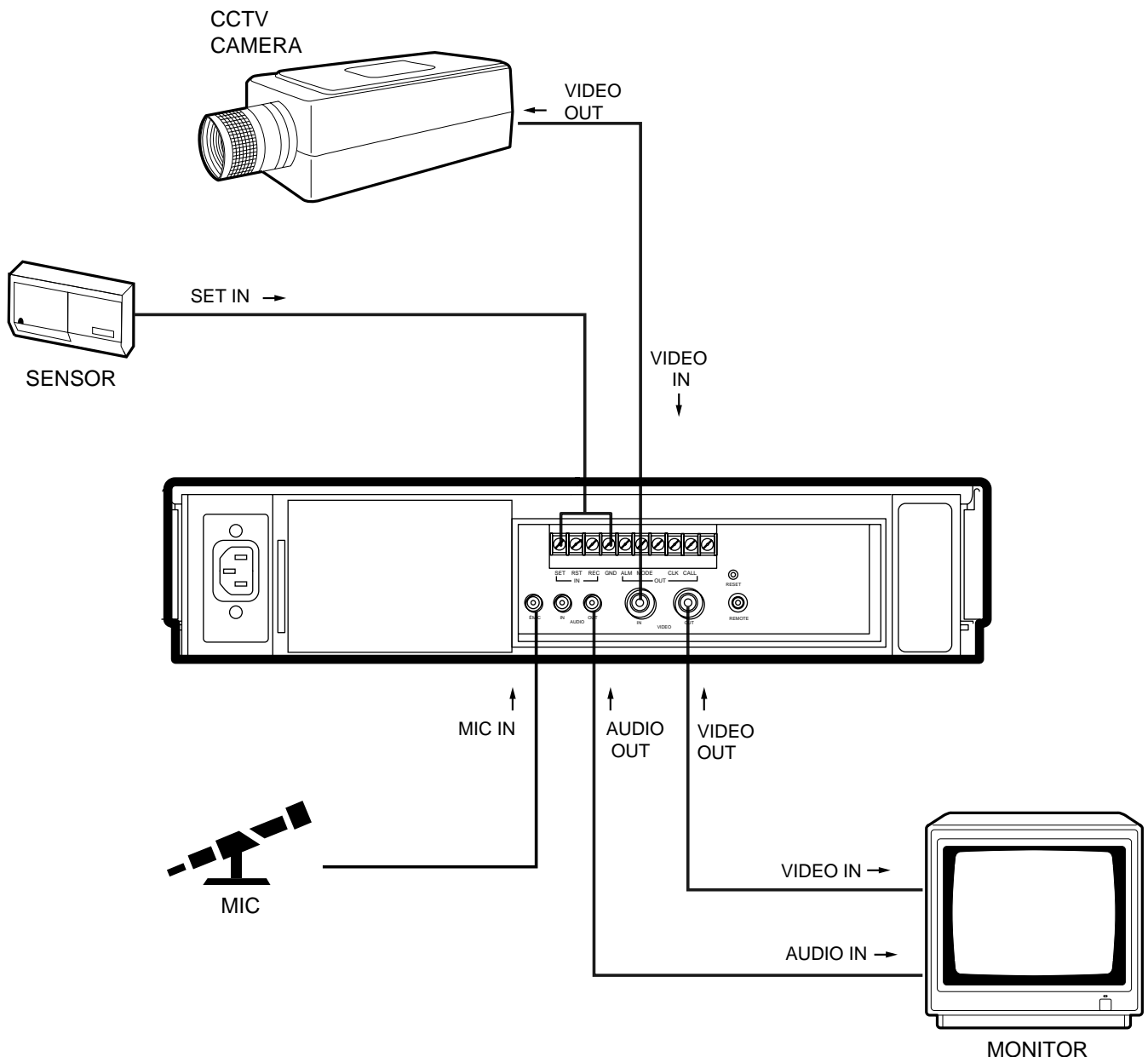

VERTICAL ADJUSTMENT (Correcting picture vibration at the top and bottom)

The picture vibration can be reduced or eliminated by the following steps.

- 1 If the vibration occurs in still, slow motion, fast playback (x2) or normal playback in 24H - 168H or 0H mode, playback a tape which is recorded in 3H or 6H mode with this VCR and press the PAUSE button.
If the vibration occurs during normal playback in L18H or L24H mode, playback a tape in each playback mode.
- 2 Press the VERTICAL ADJUST(+) or (-) button to reduce or eliminate the picture vibration.

MONITOR TO BE CONNECTED

- Connection with a CCTV monitor (for surveillance) is recommended.
- Connecting with some monitors may cause picture vibration and/or picture distortion at the top or bottom of the image during still or normal playback.
A domestic Television Monitor may be unable to provide a stable picture without vibration and distortion.

SETTING THE MENUS

The operating parameters of this VCR are set through various on-screen menus.

Set the menus as follows:

OPERATION

- 1 Press the DISPLAY button.
 - The "MAIN MENU" is displayed.
- 2 Turn the JOG dial to select the desired item.
 - When the JOG dial is turned to the right, the cursor moves downward.
 - When the JOG dial is turned to the left, the cursor moves upward.
- 3 Turn the SHUTTLE ring to the right.

The desired item is selected and the menu will appear.
- 4 Turn the JOG dial to select item.
- 5 Turn the SHUTTLE ring to the right and the setting item will flash.
- 6 Turn the JOG dial to change the setting.
- 7 Turn the SHUTTLE ring to the right to set.
- 8 Press the DISPLAY button.
 - The present time display will appear.

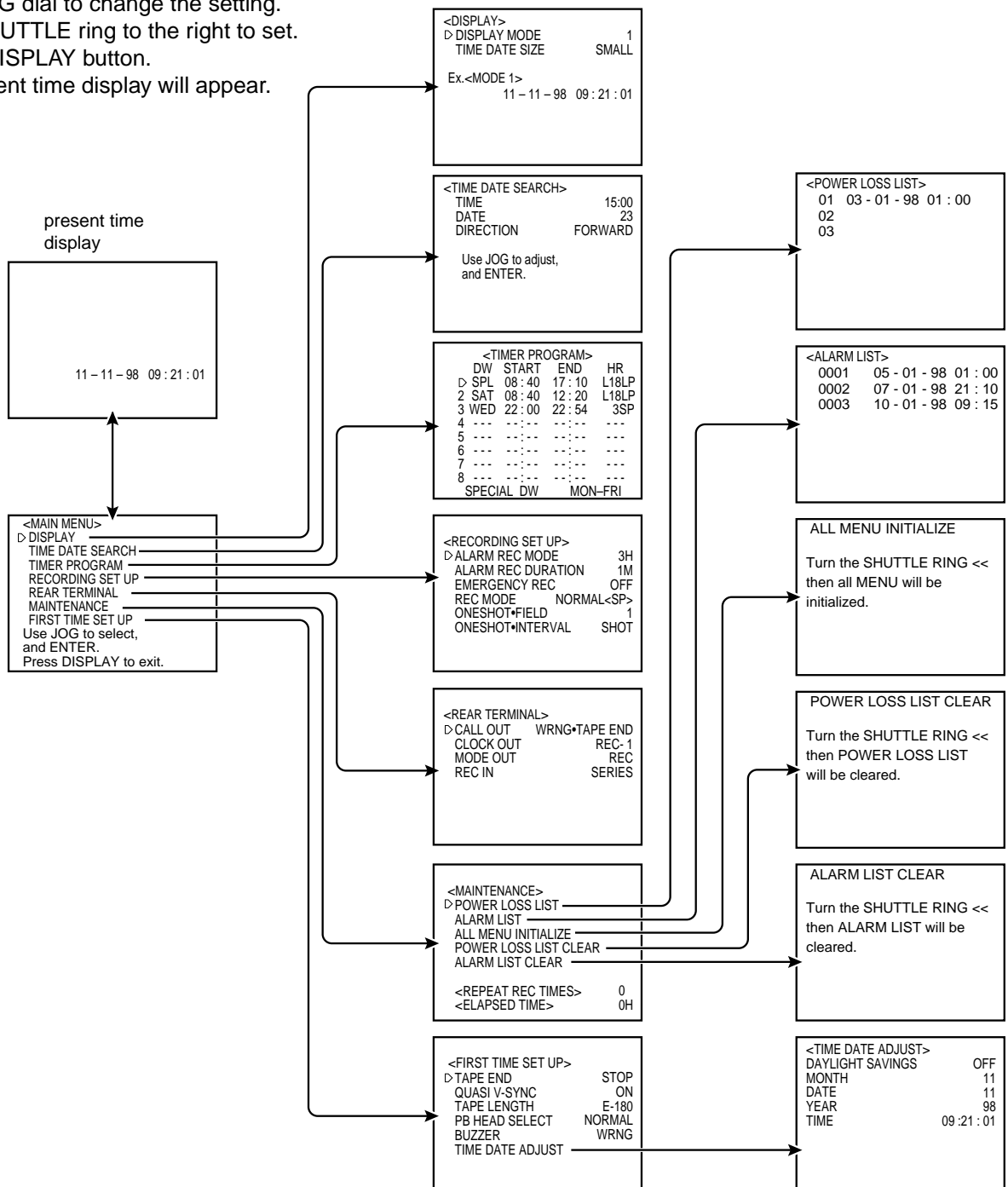

MAIN MENU

- 1 DISPLAY**
Sets the display format of the date and present time on the monitor.
- 2 TIME DATE SEARCH**
Sets the date, time and direction to search for the desired part of a tape.
- 3 TIMER PROGRAM**
Sets the timer recording.
- 4 RECORDING SET UP**
Sets the alarm recording mode, alarm recording duration, emergency recording, recording mode and one-shot recording.
- 5 REAR TERMINAL**
Sets the frequency division ratio of CLOCK OUT, output signal of the CALL OUT terminal and the MODE OUT terminal, etc.
- 6 MAINTENANCE**
Displays the power loss list and alarm loss list, etc. and initialises all menu settings. Clears the power loss list and alarm list.
- 7 FIRST TIME SET UP**
Set up for when the end of the tape is reached, quasi v-sync, tape length, playback head selection, buzzer setting, present time.

```
<MAIN MENU>
▷ DISPLAY
  TIME DATE SEARCH
  TIMER PROGRAM
  RECORDING SET UP
  REAR TERMINAL
  MAINTENANCE
  FIRST TIME SET UP
  Use JOG to select,
  and ENTER.
  Press DISPLAY to exit.
```

DISPLAY

- 1 SETTING THE DISPLAY MODE (DISPLAY MODE)**
 DISPLAY MODE 1: Displays date and present time. (Refer to page 11.)
 DISPLAY MODE 2: Displays date, day of the week, present time and recording mode. (Refer to page 11.)
 DISPLAY MODE 3: Displays nothing; until an alarm recording starts, then date, alarm recording number, etc. is displayed.
 DISPLAY MODE 4: Displays nothing; even in the case of alarm recording, nothing is displayed on the monitor.
 - During an alarm recording, alarm recording number is displayed if the "DISPLAY MODE" is set from 1 to 3.
- 2 SETTING THE SIZE OF THE LETTERS OF DAY AND PRESENT TIME DISPLAY (TIME DATE SIZE)**
 SMALL: The size of the letters becomes small.
 LARGE: The size of the letters becomes large.

```
<DISPLAY>
▷ DISPLAY MODE          1
  TIME DATE SIZE      SMALL
Ex.<MODE 1>
      11 - 11 - 98  09 : 21 : 01
```

TIME DATE SEARCH

Sets the date, time and direction to search for the desired location on a tape.

- 1 SETTING THE TIME** Turn the JOG dial to set the hour and minute to search for.
- 2 SETTING THE DATE** Turn the JOG dial to set the day of the month to search for.
- 3 SETTING THE DIRECTION** Turn the JOG dial to select the starting direction for search.
 FORWARD: Search in the forward direction.
 REVERSE: Search in the reverse direction.
 - If the desired part of a tape is not found in one direction, the VCR automatically searches in the opposite direction.

```
<TIME DATE SEARCH>
  TIME
  DATE
  DIRECTION
  FORWARD
  Use JOG to adjust,
  and ENTER.
```

After the setting, turn the SHUTTLE ring to the right to start searching.

NOTE:

- An hour index mark is written on the tape on the hour and is used as a reference in the search function. Because of this, a recorded tape must pass a time clock hour mark before this function can work. The TIME DATE SEARCH function begins after the first hour index mark.
 Example 1: VCR is set to record from 8:30 to 17:30 - Times from 9:00 to 17:30 can be found.
 Example 2: VCR is set to record in one speed from 7:00 to 14:30, then in another speed until 18:00 - Times from 7:00 to 14:30 and 15:00 to 18:00 are accurately located.
- Time date search function is not available for a tape recorded by any other VCR than this model.
- If recording quality is poor, the VCR may fail to locate the desired part of the tape during time date search.

TIMER PROGRAM

Refer to page 18 "TIMER RECORDING" for details.

RECORDING SET UP

- 1 SETTING THE ALARM REC MODE (ALARM REC MODE)**
 Sets the alarm recording time mode. When the JOG dial is turned, the display will be switched in the order of 3H → 6H → L18H → L24H → 3H →
- 2 SETTING THE ALARM REC DURATION (ALARM REC DURATION)**
 Sets the duration of the alarm recording period. When the JOG dial is turned, the display will be switched in the order of 1M(minute) → 2M → 5M → 10M → MAN1 → MAN2 → 15S(second) → 30S → 45S → 1M → Refer to "ALARM RECORDING" on page 20.
- 3 SETTING THE EMERGENCY REC (EMERGENCY REC)**
 Sets the emergency recording mode.
 OFF: Starts alarm recording when the alarm signal is received during recording.
 ON: Starts alarm recording when the alarm signal is received not only during recording but also when the power is OFF or when the tape is stopped.

```
<RECORDING SET UP>
▷ ALARM REC MODE      3H
  ALARM REC DURATION  1M
  EMERGENCY REC       OFF
  REC MODE             NORMAL<SP>
  ONESHOT*FIELD        1
  ONESHOT*INTERVAL    SHOT
```

SETTING THE MENUS

4 RECORDING MODE (REC MODE)

Sets the recording mode.

NORMAL<SP> : Choose when higher picture quality is preferred. With this setting, the recording time mode is switched in the order of 3H → L24H → 48H → 72H → 96H → 120H → 168H → 0H → 3H ...

H•D<LP> : Select a LP setting to perform High Density recording. This provides 2x more fields than Normal Density(SP). It reduces the time interval between pictures, providing more pictures for smoother time lapse recording. With this setting, the recording time mode is switched in the order of 6H → L18H → 48H → 72H → 96H → 120H → 168H → 0H → 6H ...

5 SETTING THE NUMBER OF FIELDS IN ONE-SHOT RECORDING (ONE SHOT•FIELD)

Sets the number of recorded fields in the one-shot recording mode. When the JOG dial is turned to the right, the display will be switched in the order of 1 → 2 → 3 → 4 → 5 → 10 → 20 → 30 → 1 → ...

6 SETTING THE INTERVAL TIME IN THE ONE-SHOT RECORDING MODE (ONE SHOT•INTERVAL)

Sets the interval time in the one-shot recording mode. When the JOG dial is turned to the right, the display will be switched in the order of SHOT → 10S (second) → 15S → 30S → 45S → 1M → 2M → 3M → SHOT → ...

REAR TERMINAL

<REAR TERMINAL>	
▷ CALL OUT	WRNG•TAPE END
CLOCK OUT	REC-1
MODE OUT	REC
REC IN	SERIES

1 SETTING THE CALL SIGNAL OUTPUT AT THE END OF THE TAPE (CALL OUT)

Enables or disables the signal that is output from the CALL terminal when the end of the tape is reached during recording. If any abnormalities occur during recording, a CALL signal is output from the CALL terminal on the rear panel regardless of CALL OUT setting.

WRNG•TAPE END: A signal is output at the end of the tape or when a malfunction occurs.

WRNG•REMAIN: The signal is output when a malfunction occurs in this VCR or when the tape has approximately 3 minutes left in 3H mode.

WRNG: When a malfunction occurs in the VCR during recording, a CALL signal is output.

This is used in conjunction with TAPE END (FIRST TIME SET UP) to determine when the CALL signal is output as shown below.

CALL OUT setting		TAPE END setting	WRNG•TAPE END	WRNG•REMAIN	WRNG
		STOP	Outputs a call signal at the end of the tape	Outputs 3 minutes before the tape end	When a malfunction occurs in the VCR during recording, a call signal is output.
REWIND		Outputs a call signal at the end of the tape for 2 seconds	↑	↑	
REPEAT		↑	↑	↑	
ALARM • PROT	When there are no alarm recordings during recording	↑	↑	↑	
	When there are alarm recordings during recording	Outputs a call signal at the end of the tape	↑	↑	

2 SETTING THE FREQUENCY DIVISION RATIO (CLOCK OUT)

Sets the frequency division ratio of the CLOCK OUT terminal.

First, set the recording mode for the "CLOCK OUT" pulse output in the "REAR TERMINAL" menu.

REC: When recording in any mode.

T/L-REC: When recording in time lapse mode (L18H, L24H, 48H, 72H, 96H, 120H, 168H or 0H).

Second, select the frequency division ratio setting by turning the SHUTTLE ring. When the JOG dial is turned, the display will be switched in the order of 1 → 2 → 3 → 4 → 5 → 10 → 15 → 20 → 25 → 30 → 50 → 60 → F (field) → 1 → ... The numbers from 1 to 60 indicate the number of frames in 3H or 6H recording mode or the number of fields in time lapse recording mode. (One frame consists of two fields.) One field is selected when it is set to "F" (field).

3 SETTING THE OPERATION MODE OF THE MODE OUTPUT TERMINAL (MODE OUT)

Set the state in which the signal output at the MODE OUT terminal is switched to the active condition. When the JOG dial is turned, the display will be switched on in the order of REC (recording) → PLAY (playback) → POWER (power "ON") → TAPE IN (tape is inserted) → TAPE REMAIN (3 minutes in 3H mode before the tape end) → CLOCK ADJ (output the signal for 1 second when the clock indicates "00(min.):00(sec.)") → REC.

4 SETTING THE OPERATION MODE OF THE REC IN TERMINAL (REC IN)

SERIES: Recording starts when the REC IN terminal is short-circuited to ground or a "L" level voltage (0 - +1.6V) is applied.

REC-START/ STOP: Recording starts when the REC IN terminal is short-circuited to ground or a "L" level voltage (0 - +1.6V) is applied. Should this connection be removed, recording will stop.

SYNC REC: The video signal from 3 or 9 cameras can be recorded separately by connecting the switcher. ("SYNC REC" function is available when recording in L18H or L24H mode.) Refer to "SYNCHRONOUS RECORDING" on page 16.

MAINTENANCE

1 DISPLAYING THE POWER LOSS LIST (POWER LOSS LIST)

Turn the JOG dial to select "POWER LOSS LIST". Turn the SHUTTLE ring to the right to display the Power Loss List. Power failure start times are stored in memory, so it is possible to confirm when they have occurred. Up to 3 power failure start times will be displayed. If more than 3 failures have occurred, the first and last 2 power failure start times will be displayed.

```
<MAINTENANCE>
▷ POWER LOSS LIST
  ALARM LIST
  ALL MENU INITIALIZE
  POWER LOSS LIST CLEAR
  ALARM LIST CLEAR

<REPEAT REC TIMES>    0
<ELAPSED TIME>       0H
```

2 DISPLAYING THE ALARM LIST (ALARM LIST)

Turn the JOG dial to select "ALARM LIST". Turn the SHUTTLE ring to the right to display the Alarm List. Alarm record start times are stored in memory, so it is possible to confirm when they have occurred. Up to 3 alarm record start times will be displayed. If more than 3 alarm records have occurred, the first and the last 2 alarm record start times will be displayed.

3 INITIALIZING ALL MENU SETTINGS (ALL MENU INITIALIZE)

Turn the SHUTTLE ring to the right and "ALL MENU INITIALIZE" will be displayed. When the SHUTTLE ring is turned to the left, each setting is initialised except the TIMER RECORDING setting. When the SHUTTLE ring is turned to the right, the "MAINTENANCE" menu will be displayed.

4 CLEARING THE POWER LOSS LIST (POWER LOSS LIST CLEAR)

Turn the SHUTTLE ring to the right and "POWER LOSS LIST CLEAR" will be displayed. When the SHUTTLE ring is turned to the left, the Power Loss List is cleared. When the SHUTTLE ring is turned to the right, the "MAINTENANCE" menu will be displayed.

5 CLEARING THE ALARM LIST (ALARM LIST CLEAR)

Turn the SHUTTLE ring to the right and "ALARM LIST CLEAR" will be displayed. When the SHUTTLE ring is turned to the left, the alarm list is cleared. When the SHUTTLE ring is turned to the right, the "MAINTENANCE" menu will be displayed.

FIRST TIME SET UP

1 SETTING THE OPERATION WHEN THE TAPE REACHES THE END (TAPE END)

Sets the state of operation of the VCR when the tape runs out during recording.

STOP: The tape stops. "End" will appear on the fluorescent display and "Tape End" will appear on the monitor. When "CALL OUT" is set to "WRNG•TAPE END", a CALL signal is output from the CALL terminal.

REWIND: Rewinds the tape to the beginning and stops (except during timer recording).

When "CALL OUT" is set to "WRNG•TAPE END", a CALL signal is output for 2 seconds from the CALL terminal.

REPEAT: Rewinds the tape to the beginning and resumes recording.

ALARM•PROT(ALARM PROTECTION):

If alarm recordings are present on the tape, then the tape stops. "End" will appear on the fluorescent display and "Tape End" will appear on the monitor. When "CALL OUT" is set to "WRNG•TAPE END", a CALL signal is output from the CALL terminal. If there are no alarm recordings, the tape is rewound and recording continues.

```
<FIRST TIME SET UP>
▷ TAPE END                STOP
  QUASI V-SYNC            ON
  TAPE LENGTH             E-180
  PB HEAD SELECT          NORMAL
  BUZZER                  WRNG
  TIME DATE ADJUST
```

2 SETTING QUASI-V-SYNC (QUASI V-SYNC)

Sets Quasi-V-Sync on or off.

ON: Quasi-V-Sync signal is inserted on the video output signal when in the special playback modes (still, slow motion, reverse, fast playback, speed search) and during normal playback in L18H, L24H, 24H - 168H or 0H mode.

OFF: Quasi-V-Sync signal is not inserted.

NOTE: Some multiplexers may require the Quasi-V-sync OFF in order to work properly.

3 SETTING THE TAPE LENGTH (TAPE LENGTH)

For the tape indicator to operate correctly the tape length must be set according to the tape being used.

E-180: When using E-180 tape

E-240: When using E-240 tape

4 SETTING THE HEADS FOR PLAYBACK (PB HEAD SELECT)

Sets the heads for playback. When the JOG dial is turned to the right, the display will be switched in the order of NORMAL → L/L (LEFT/LEFT) → R/R (RIGHT/RIGHT) → AUTO → NORMAL → ...

- This VCR is equipped with two pairs of SP heads. Some VCRs make Time Lapse recordings using same Azimuth heads which are not VHS compatible. Playback of such tapes with the Normal setting will have picture/noise with a 30 HZ flicker, or just noise. To obtain proper playback, adjust the setting to AUTO, or set to L/L or R/R. One setting will provide normal play. After playing a tape with L/L or R/R settings, return the setting to NORMAL.

5 SETTING THE BUZZER ON/OFF (BUZZER)

Sets the state in which the buzzer sounds.

WRNG : The buzzer sounds when there is any malfunction in the VCR.

WRNG•REMAIN : The buzzer sounds when there is any malfunction in the VCR or when the tape (E-180 or E-240) has approximately 3 minutes left in 3H mode.

WRNG•TAPE END : The buzzer sounds when there is any malfunction in the VCR or at the tape end.

OFF : The buzzer does not sound.

6 SETTING THE PRESENT TIME, DATE AND DAYLIGHT SAVING TIME SETTINGS (TIME DATE ADJUST)

Refer to the pages 11 - 12.

SETTING THE PRESENT TIME

ACCURATELY PRESET THE DAY AND PRESENT TIME BEFORE TIMER PROGRAMMING

<Display mode 1>

- ① Day-Month-Year
- ② Hour:Minute:Second
- ③ Daylight saving time symbol or power failure symbol
- ④ Alarm recording number

- A 24-hour display is used. 00:00 indicates midnight; 12:00 midday and 15:00 indicates 3 o'clock in the afternoon.
- An alarm recording number is shown during alarm recording.

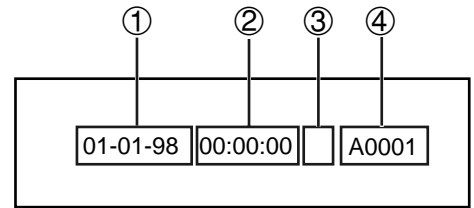

<Display mode 2>

- ① Day-Month-Year
- ② Day of the week
- ③ Alarm recording number
- ④ Hour:Minute:Second
- ⑤ Daylight saving time symbol or power failure symbol
- ⑥ Recording mode

- A 24-hour display is used. 00:00 indicates midnight; 12:00 midday and 15:00 indicates 3 o'clock in the afternoon.
- The day of the week is automatically set.
- An alarm recording number is shown during alarm recording.

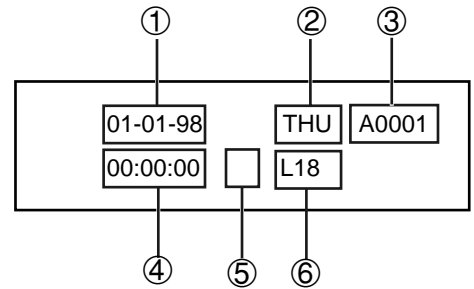

- 1 Press the DISPLAY button to display MAIN MENU on the monitor.



```

<MAIN MENU>
▷ DISPLAY
TIME DATE SEARCH
TIMER PROGRAM
RECORDING SET UP
REAR TERMINAL
MAINTENANCE
FIRST TIME SET UP
Use JOG to select,
and ENTER.
Press DISPLAY to exit.
    
```

- 2 Turn the JOG dial to select "FIRST TIME SET UP".



```

<MAIN MENU>
DISPLAY
TIME DATE SEARCH
TIMER PROGRAM
RECORDING SET UP
REAR TERMINAL
MAINTENANCE
▷ FIRST TIME SET UP
Use JOG to select,
and ENTER.
Press DISPLAY to exit.
    
```

- 3 Turn the SHUTTLE ring to the right .
 - "FIRST TIME SET UP" setting menu will appear.

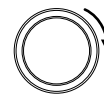

```

<FIRST TIME SET UP>
▷ TAPE END                STOP
  QUASI V-SYNC            ON
  TAPE LENGTH             E-180
  PB HEAD SELECT         NORMAL
  BUZZER                  WRNG
  TIME DATE ADJUST
    
```

- 4 Turn the JOG dial to select "TIME DATE ADJUST".



```

<FIRST TIME SET UP>
TAPE END                STOP
  QUASI V-SYNC            ON
  TAPE LENGTH             E-180
  PB HEAD SELECT         NORMAL
  BUZZER                  WRNG
▷ TIME DATE ADJUST
    
```

- 5 Turn the SHUTTLE ring to the right.
 - "TIME DATE ADJUST" setting menu will appear.



```

<TIME DATE ADJUST>
DAYLIGHT SAVINGS      OFF
MONTH                  01
DATE                   01
YEAR                   98
TIME                   00 :00 : 00
    
```

6 Setting the daylight saving time

To put the clock forward 1 hour, set DAYLIGHT SAVINGS to ON.
Turn the SHUTTLE ring to the right. The DAYLIGHT SAVINGS display will flash.
Turn the JOG dial to switch "OFF" or "ON".

- The clock is put forward 1 hour and the daylight saving time symbol "☀" will be displayed next to the present time display .
- To cancel daylight saving time, switch "DAYLIGHT SAVINGS" to "OFF".

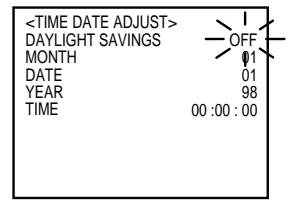
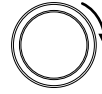

NOTE:

- Should a power failure occur while daylight saving time is selected, the power failure mark "X" will replace the daylight saving time symbol. When the power failure mark "X" disappears, the daylight saving time symbol "☀" will reappear.

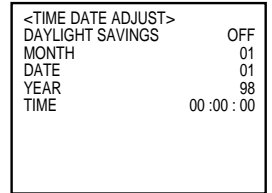

7 Setting the month

Turn the SHUTTLE ring to the right. The month display will flash.
Turn the JOG dial to the right to set the "MONTH".

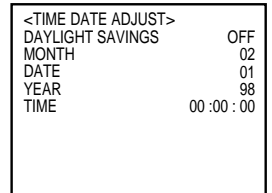
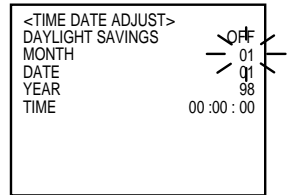
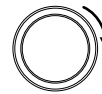

8 Setting the date

Turn the SHUTTLE ring to the right. The date display will flash.
Turn the JOG dial to the right to set the "DATE".

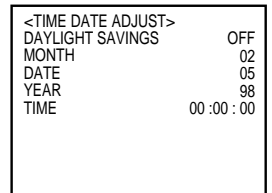
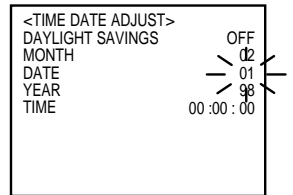

9 Setting the year

Turn the SHUTTLE ring to the right. The year display will flash.
Turn the JOG dial to the right to set the "YEAR".

- The year digits can be set to 98 (for year 1998) - 28 (for year 2028).

10 Setting the present time

Turn the SHUTTLE ring to the right. The hour digits of "TIME" display will flash.
Turn the JOG dial to the right to set the hour digits of the present time.

- Set the 10 minutes digit and 1 minute digit in a similar fashion.

11 Turn the SHUTTLE ring to the right.
Setting is now complete.

12 Press the DISPLAY button.
The present time display will appear.

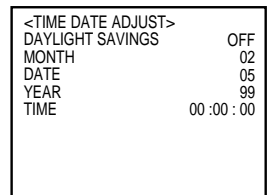
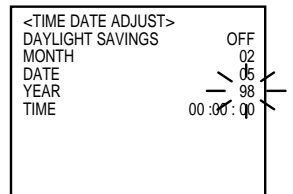

NOTE:

- The POWER button will not operate if any of the menu displays are flashing.

SETTING THE PRESENT TIME TO THE EXACT SECOND

Set the 10 minutes digit and 1 minute digit as described above, then 1 minute digit flashes and the second digit stays at "00". Turn the SHUTTLE ring to the right when the Time Signal reaches 00 second of the time you have set. The present time will start counting from 00 second.

LOADING AND UNLOADING THE CASSETTE TAPE

Video cassette tapes can be loaded into your new VCR as long as the VCR is plugged into a power source. Even if the VCR power switch is turned off, loading a cassette will automatically cause it to turn on. Use only video cassette tapes marked **VHS**.

Use only standard grade VHS cassette tapes for reliable video recording. Please do not use Pro, Hi-Fi and High Grade tapes, as damage to the video heads may occur.

Do not use an E-240 tape when recording in 48H - 168H or 0H mode.

LOADING

- 1 To position the cassette properly before inserting it in the cassette slot, hold the cassette so that the long narrow edge with the contents label faces towards you. The other long narrow edge is hinged and should face towards the VCR. The clear plastic window that shows the video tape should face upward.
- 2 Gently insert the videotape into the cassette slot to a point where the VCR automatically retracts the cassette.
 - When you insert the videotape, be sure to orient it squarely to the slot.

NOTE:

Your new VCR has a protection circuit which will eject the tape if it is loaded improperly. If the VCR ejects the tape you are trying to load, remove it completely and check that the long narrow edge with the contents label is facing towards you and that the clear plastic window that shows the video tape is facing upwards. Then try again.

UNLOADING

- 1 Press the EJECT button on the front of the VCR.
- 2 Remove the cassette.

NOTE:

Your VCR will eject a video cassette even if it is in STANDBY mode. When the EJECT button is pressed, the VCR will automatically turn on, eject the tape and turn off. It is not possible to eject a tape whilst recording without first pressing the STOP button. A tape cannot be ejected when the VCR is locked.

PREVENTING ACCIDENTAL ERASURE

Video cassettes come with an erasure prevention tab which, when removed, prevents the tape's contents from being erased or recorded over. A cassette without the erasure prevention tab will automatically be ejected from your VCR if you attempt to record on it.

NOTE:

- We recommend that any torn or broken cassette tape requiring repair should be taken to professionals who specialise in such procedures. The adhesives on many common types of tape could damage the head of your VCR.

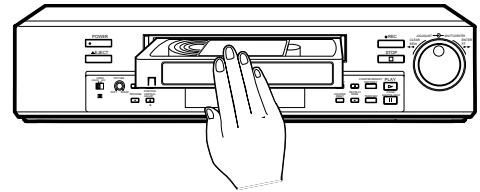

CORRECT

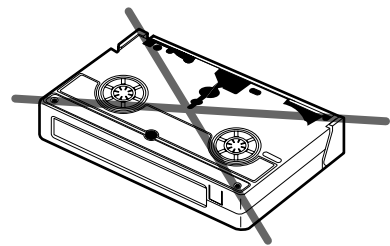

INCORRECT

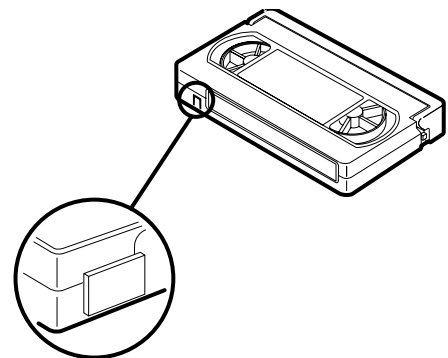

MANUAL RECORDING

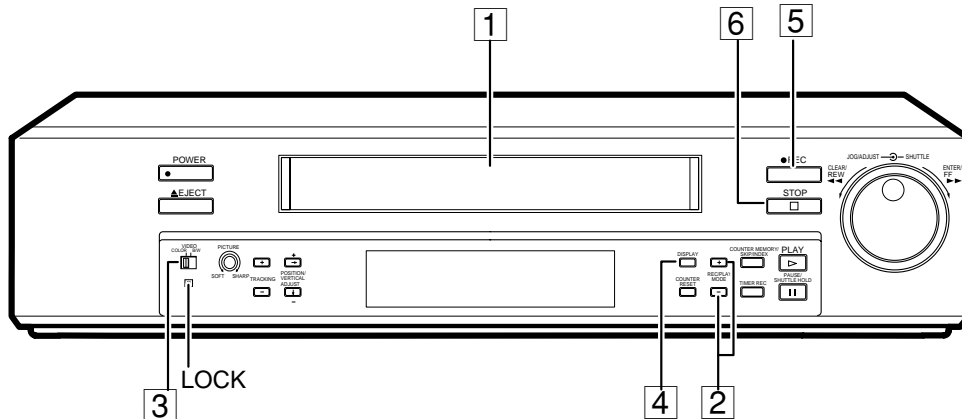

- 1 Load a cassette with the erasure prevention tab intact.
- 2 Press the REC/PLAY MODE (-) or (+) button to select the desired recording mode.
 - If necessary, change the recording mode. (See page 9.)
- 3 Select the VIDEO switch setting according to the type of image to be recorded, COLOR or B/W.
 - Do not connect color and black & white cameras together.
- 4 To record the day and present time, display the day and present time on the monitor.
- 5 Press the REC button to begin recording.
- 6 Press the STOP button to stop recording.

NOTE:

- Press the PAUSE/SHUTTLE HOLD button to momentarily stop recording. Press the button again to resume recording.
- To protect the tape, the pause mode is automatically released after about 5 minutes.
- The REC button will not function unless the tape is in the stop or pause mode.
- If the cassette you insert in your VCR has the erasure prevention tab removed, your VCR will automatically eject it if you attempt to record on it.
- 3-Hour (SP) and 6-Hour (LP) tapes are VHS compatible with other VCRs. Time Lapse recordings can be played correctly by other VHS compatible Time Lapse Recorders when the recording interval and head type (SP/LP) matches the recording.

RECORDING MODE

In SP mode, when the REC/PLAY MODE button is pressed, the recording mode is switched in the order of 3H → L24H → 48H → 72H → 96H → 120H → 168H → 0H → 3H → ...

In LP mode, when the REC/PLAY MODE button is pressed, the recording mode is switched in the order of 6H → L18H → 48H → 72H → 96H → 120H → 168H → 0H → 6H → ...

NOTE:

- Do not use an E-240 tape when recording in 48H - 168H or 0H mode.
- The recording mode of this VCR indicates the recording time with E-180 cassette. The recording times with E-180 and E-240 cassette are as follows :

	REC MODE	3H	6H	L18H	L24H	48H	72H	96H	120H	168H
E-180	SP	3	-	-	27	51	75	99	123	171
	LP	-	6	18	-	54	78	102	126	174
E-240	SP	4	-	-	36	X	X	X	X	X
	LP	-	8	24	-	X	X	X	X	X

RECORDING CHECK FUNCTION

When the VCR is recording, press the PLAY button for more than 1.5 seconds and then release. The tape will be rewind a little and then playback the recording just made. When the tape reaches the position where the PLAY button was pressed, the VCR returns to record mode.

AUDIO RECORDING

Either apply the specified line input signal to the AUDIO IN connector or connect the microphone to the MIC IN jack. If both are connected, the microphone is given priority.

NOTE:

- Normal sound is played back only when a tape recorded in 3H, 6H, L18H and L24H mode is played back in their respective mode.
- The longer the recording time mode, the worse the sound quality becomes. In L18H and L24H mode, the sound quality is of the degree that speech can be heard.

LOCK MODE

When the lock button is pressed with a ballpoint pen or a pencil, the control buttons will not operate and the VCR is kept in the current mode. To release the lock mode, press the lock button again.

MANUAL RECORDING

REPEAT RECORDING

When the "TAPE END" of the "FIRST TIME SET UP" menu is set to "REPEAT" or "ALARM•PROT" and the repeat recording mode is set (the REPEAT indicator is illuminated), the tape will automatically be rewound to the start when the tape end is reached. Then recording will start again.

■ WHEN TAPE END IS REACHED

The following functions are automatically engaged when the tape ends during recording :

	STOP	REWIND	REPEAT	ALARM•PROT
When there are alarm recordings on tape.	The tape stops.	The tape is rewound automatically to the beginning and then stops.	The tape is rewound automatically to the beginning and recording is resumed.	The tape stops.
When there are no alarm recordings on tape.				The tape is rewound automatically to the beginning and then the recording is resumed.

NOTE:

- On "ALARM•PROT" mode, a tape with alarm recordings can be used for repeat recording if the tape is ejected and re-inserted.

THE NUMBER OF TAPE USE (REPEAT REC TIMES)

Displays the number of tape use when the TAPE END setting is set to "REWIND", "REPEAT" or "ALARM•PROT".

- Press the DISPLAY button. MAIN MENU display will appear.
- Turn the jog dial to select "MAINTENANCE" and turn the SHUTTLE ring to the right to enter. "MAINTENANCE" will appear on the display. "REPEAT REC TIMES" indicates the number of times a tape has been repeatedly recorded on.
 - The number of tape use counts up by one when the tape ends.
 - The number of tape use is memorised even if the mains supply is removed, provided the backup is active.
 - The number of tape use is reset when the current tape is replaced with another.
- Press the DISPLAY button. The present time will be displayed.

<REPEAT REC TIMES>	0
<ELAPSED TIME>	0H

RECOMMENDED NUMBER OF TAPE USE

Video tape becomes worn during use. A new cassette should be utilised according to the following chart.

Recording time mode	Number of tape use		Recording time mode	Number of tape use	
	E-180 cassette	E-240 cassette		E-180 cassette	E-240 cassette
3H, 6H	100	50	72H, 96H	15	—
L18H	60	30	120H	10	—
L24H	35	17	168H	8	—
48H	20	—			

SERIES RECORDING

Series recording is possible if two or more of these units are connected together. When the tape in the first VCR reaches the end during recording, the tape in the second VCR automatically begins recording.

- Set the "REC IN" of "REAR TERMINAL" menu to "SERIES".
- Set the "CALL OUT" of "REAR TERMINAL" menu to "WRNG•TAPE END".
- Set the "TAPE END" of "FIRST TIME SET UP" menu to "REWIND".

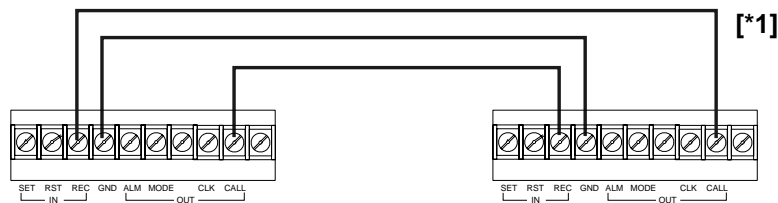

NOTE:

- Series recording may have a short pause (≈ 5 seconds) when going from recorder A to recorder B. However, if you set the CALL OUT of the "REAR TERMINAL" menu to "WRNG•REMAIN", this delay is eliminated.
- When set in the above configuration and the second VCR reaches the end of the tape, the first VCR automatically begins recording. Do not connect [*1], if you do not require the first VCR to begin recording again.
- If an abnormality occurs (eg., a malfunction occurs in the motor during recording) in the first VCR, the second VCR automatically begins recording.
- Series recording will not function during timer recording.
- When carrying out series recording, set "CALL OUT" in the "REAR TERMINAL" menu to a mode other than "WRNG".

ONE SHOT/INTERVAL RECORDING

One-shot recording or Interval recording is possible when the recording mode is set to 0H.

- 1 Press the REC/PLAY MODE button to set the recording mode to 0H.
- 2 Set the number of fields in "ONE SHOT•FIELD" on the "RECORDING SET UP" menu.
- 3 For One-shot recording, select "SHOT" in "ONE SHOT•INTERVAL".
For Interval recording, choose the interval time from 10S(second) to 3M(minute) in "ONE SHOT•INTERVAL".
- 4 Press the REC button.
 - One-shot recording will be on STANDBY mode. Interval recording begins recording with the preset interval time.
- 5 To start One-shot recording, press the REC button or switch the REC IN terminal on the rear panel to ground.

SYNCHRONOUS RECORDING

A number of camera images can be mixed together through a camera switcher and then recorded separately onto several VCRs. A camera is assigned to each VCR with the VCR recording only the camera image it has been assigned. This allows recording without gaps.

If you have three VCRs, the video signal from three cameras can be recorded separately by connecting the switcher as shown below.

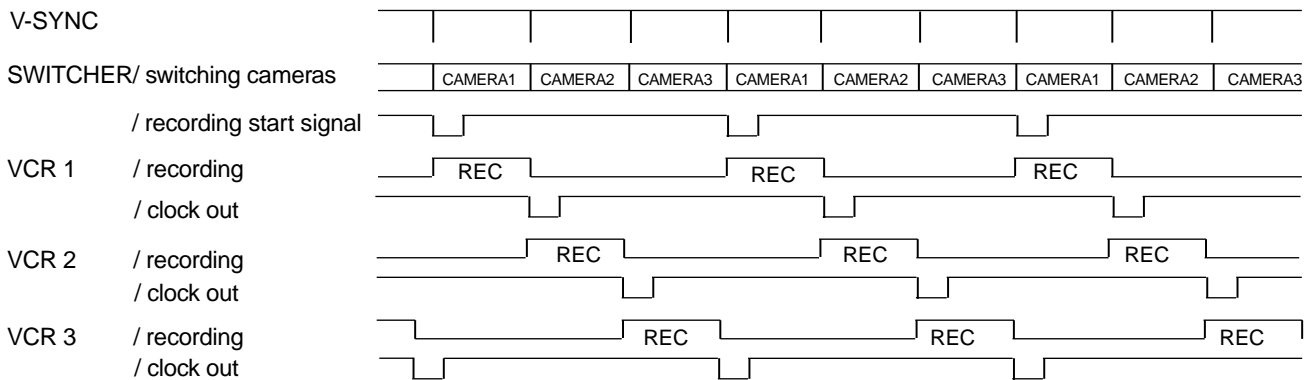

Connection:

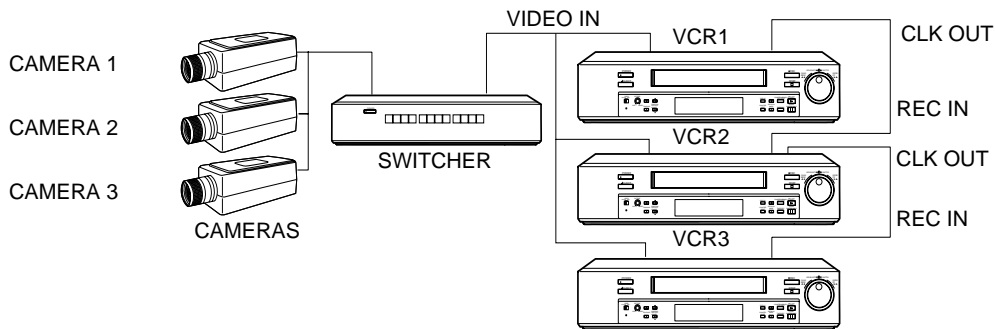

Set the "REC IN" of "REAR TERMINAL" menu to "SERIES" or "REC-START/STOP" on VCR1.

Set the "CLOCK OUT" of "REAR TERMINAL" menu to "T/L-REC" and "F" on VCR1.

Set the "REC IN" of "REAR TERMINAL" menu to "SYNC REC" on all VCRs except VCR1.

- If a recording start signal is available on the switcher, set "REC IN" of the "REAR TERMINAL" menu to "SYNC REC" on VCR1. Then, VCR1 will always record the picture from CAMERA1.
- You must set the recording mode to L18H or L24H mode.
- The suitable numbers of VCRs and cameras are shown in the table.

Recording mode	VCR	Camera
L18H	3	Multiple of 3
L24H	9	Multiple of 9

ADDITIONAL FEATURES

COUNTER MEMORY

Press the COUNTER MEMORY/SKIP/INDEX button repeatedly until the "M" indicator appears on the fluorescent display. Turn the SHUTTLE ring to the right and the tape will rewind to the "00000" position of the counter and stop. (The rewind to "00000" is slightly inaccurate.)

NOTE: The counter display is stored in the memory when the power is turned off, so the same numbers will be displayed when the power is turned back on.

TAPE COUNTER

A five digit counter indicates the relative position on the recorded portion of the tape. If a portion of the tape is not recorded, the counter will not increase or decrease during play, FF/RWD or search modes.



- "EEE EE" illuminates to indicate that the VCR power is in stand-by mode.

COUNTER RESET

Press the COUNTER RESET button to reset the counter to "00000".

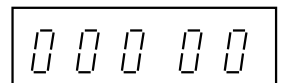

MEMORY BACK-UP IN CASE OF POWER FAILURE

This VCR includes a built-in memory back-up so the presets of present time and date, alarm list, power loss list and the number of tape use will remain in memory if there is a power failure or if the POWER CORD is disconnected from the mains outlet. The presets will remain in the memory for a maximum of 31 days as long as the VCR has been connected to the mains supply for at least 40 hours per week. Connection charges the backup supply.

- Check the present time if there has been a power failure or if the POWER CORD has been disconnected from the mains for a prolonged time.

RECORDING AFTER A POWER FAILURE

If there is a power failure during recording and the power comes back on, the VCR will begin recording in the same record mode as before the power failure. After the power comes back on, "X" will be displayed next to the present time for about 1 minute.

If a power failure occurs during playback, the VCR will be in the stop mode when the power comes back on.

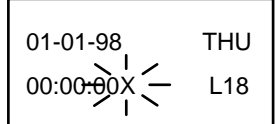

POWER FAILURE TIME DISPLAY

The power failure start time on recording is stored in the memory, so it is possible to confirm the start time.

1. Press the DISPLAY button to display the MAIN MENU.
2. Turn the JOG dial to select "MAINTENANCE" and turn the SHUTTLE ring to the right. "MAINTENANCE" display will appear.
3. Turn the JOG dial to select "POWER LOSS LIST" and turn the SHUTTLE ring to the right. "POWER LOSS LIST" will appear.

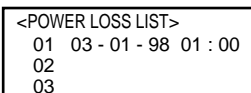

- Up to 3 power failure start times will be displayed. If more than 3 failures have occurred, the first and the last 2 power failure start times will be displayed.
- To reset the "POWER LOSS LIST", select "POWER LOSS LIST CLEAR" in the "MAINTENANCE" setting display and turn the SHUTTLE ring to the right. The initialize menu will appear and turn the SHUTTLE ring to the left.

ELAPSED TIME DISPLAY

The elapsed time of recording and playback are stored in memory. The elapsed time should be used as a guide for the periodic replacement of parts.

1. Press the DISPLAY button to display the MAIN MENU.
2. Turn the JOG dial to select "MAINTENANCE" and turn the SHUTTLE ring to the right. "ELAPSED TIME" is indicated.
 - The elapsed time counts up to 89,999 hours.
3. Press the DISPLAY button. The present time display will appear.



TIMER RECORDING

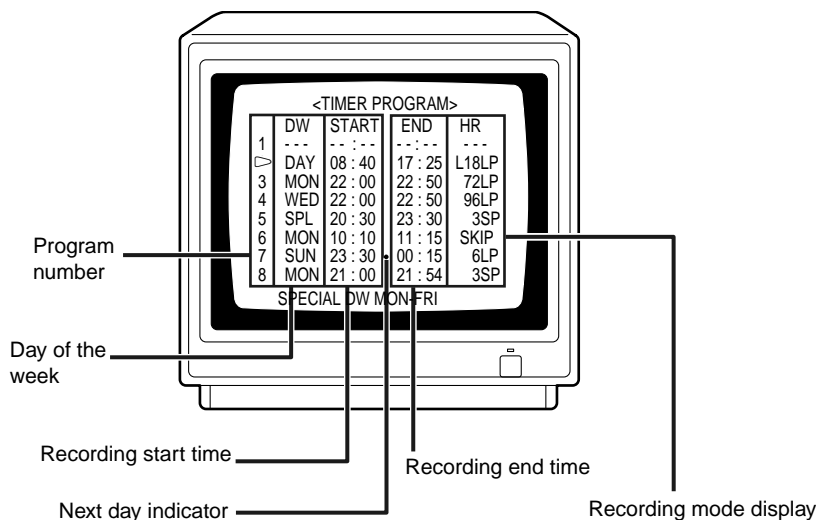

- “DAY” (in “Day of the week”) is used for the same time recording everyday.
- “SPL” (special) (in “Day of the week”) indicates that the recording period set in “TIMER PROGRAM” display becomes available.
- “SKIP” (in “HR”) indicates that timer recording is not performed during the set period.
- A 24-hour display is used. 00:00 indicates midnight; 12:00 midday and 15:00 3 o'clock in the afternoon.
- If the recording times of two programs overlap, the higher program number is given priority.
- In 3H, 6H, L18H or L24H mode, audio is also recorded.

- 1 Press the DISPLAY button to display the MAIN MENU on the monitor.
- 2 Turn the JOG dial to select “TIMER PROGRAM” and turn the SHUTTLE ring to the right.
 - “TIMER PROGRAM” display will appear.
- 3 Turn the JOG dial to select the program number and turn the SHUTTLE ring to the right. The day of the week display flashes.
- 4 Setting the day of the week (DW).
Turn the JOG dial to set the day of the week and turn the SHUTTLE ring to the right.
- 5 Setting the recording start time (START).
Turn the SHUTTLE ring to select the recording start time display.
Turn the JOG dial to set the recording start time.
- 6 Setting the recording end time (END).
Turn the SHUTTLE ring to select the recording end time display.
Turn the JOG dial to set the recording end time.
- 7 Setting the recording mode (HR).
Turn the SHUTTLE ring to select the recording mode display.
Turn the JOG dial to set the recording mode.
- 8 Turn the SHUTTLE ring to the right.
The display stops flashing.
If the program has not been set completely, the flashing will not stop.

```

<MAIN MENU>
DISPLAY
TIME DATE SEARCH
▷ TIMER PROGRAM
RECORDING SET UP
REAR TERMINAL
MAINTENANCE
FIRST TIME SET UP
Use JOG to select,
and ENTER.
Press DISPLAY to exit.
    
```

```

<TIMER PROGRAM>
DW START END HR
▷ SPL 08:40 17:10 L18LP
2 --- :--: :--: ---
    
```

```

DW START END HR
1 SPL 08:40 17:10 L18LP
▷ --- :--: :--: ---
    
```

```

DW START END HR
1 SPL 08:40 17:10 L18LP
▷ SAT --- :--: :--: ---
    
```

```

DW START END HR
1 SPL 08:40 17:10 L18LP
▷ SAT 08:00 --- :--: ---
    
```

```

DW START END HR
1 SPL 08:40 17:10 L18LP
▷ SAT 08:40 --- :--: ---
    
```

```

DW START END HR
1 SPL 08:40 17:10 L18LP
▷ SAT 08:40 12:00 --- :--: ---
    
```

```

DW START END HR
1 SPL 08:40 17:10 L18LP
▷ SAT 08:40 12:00 72LP
    
```

```

DW START END HR
1 SPL 08:40 17:10 L18LP
▷ SAT 08:40 12:00 --- :--: ---
    
```

```

DW START END HR
1 SPL 08:40 17:10 L18LP
▷ SAT 08:40 12:00 72LP
    
```

- If the END time is the same or earlier than the START time, the next day indicator (•) is automatically displayed. This indicates that the recording will run continuously from the START time on the first day to the END time on the next day.
 - When setting another program, turn the SHUTTLE ring to set and repeat steps 3 - 8. A maximum of eight programs can be made.
 - To erase the program setting, select the program number to be erased. Turn the SHUTTLE ring to the right to flash the day of the week, then turn the SHUTTLE ring to the left.
- 9 Press the DISPLAY button to show the day and present time on the monitor.
 - 10 Press the TIMER REC button.
The TIMER REC indicator is illuminated.

TIMER RECORDING

SETTING THE RECORDING PERIOD BY SPECIFYING THE DAYS OF THE WEEK (SPECIAL DW)

Set the recording period by specifying the start and end day of the week for timer recording.

1. Display the "TIMER PROGRAM" setting display.
 2. Turn the JOG dial to select "SPECIAL DW" and turn the SHUTTLE ring to the right.
 3. Turn the JOG dial to set the start day and turn the SHUTTLE ring to the right.
 4. Turn the JOG dial to set the end day and turn the SHUTTLE ring to the right.
- The start and end day cannot be set to the same day.

IN ORDER TO AVOID MISTAKES WHEN USING THE TIMER

If an error is encountered when the TIMER REC button is pressed, refer to the following table.

Symptom	Fault	Action
TIMER REC indicator flashes.	<ul style="list-style-type: none">• A tape is not inserted.• A tape with the erasure prevention tab removed is loaded.• Date, time or timer recording time is not set.• A menu is being set.	<ol style="list-style-type: none">1. Press the TIMER REC button.2. Correctly set the timer program.3. Press the TIMER REC button and confirm the TIMER REC indicator () is illuminated.

ALARM RECORDING

It is possible to switch from all recording modes to the 3H - L24H recording mode by applying an alarm signal to the SET IN terminal on the rear panel.

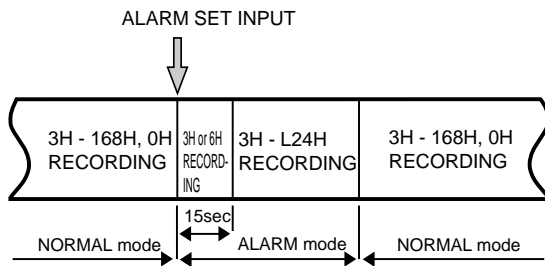

- It is possible to switch to the alarm recording by applying the set signal from the alarm sensor during recording in 3H, 6H, L18H, L24H, 48H - 168H or 0H mode.

- Set the alarm recording mode and alarm recording period with the “RECORDING SET UP” menu. (See page 8.)
- The index signal is automatically recorded when an alarm recording begins. (INDEX indicator flashes on the fluorescent display.)
- To record the index signal, the first 15 seconds of the alarm recording are in 3H or 6H mode.
- While the index signal is being recorded (for 15 seconds), if another set signal is applied to the SET IN terminal, it will not trigger a new alarm recording.

ALARM RECORDING CONNECTION

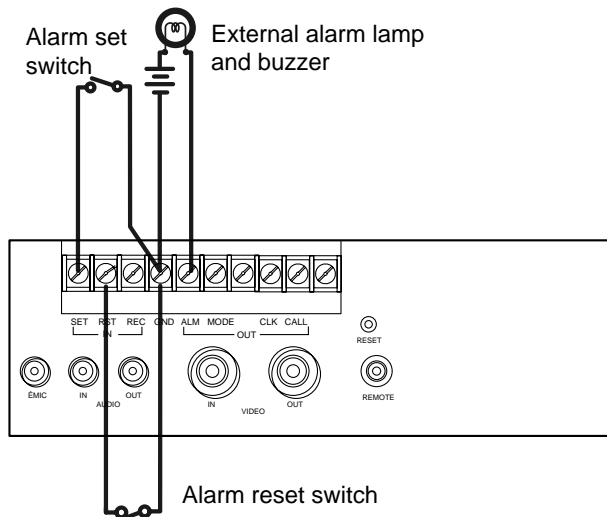

- The alarm can be confirmed from a distance by connecting the ALM (ALARM) OUT terminal to an existing alarm system panel or other external devices such as a buzzer.

EXTERNAL TIME CLOCK ADJUSTMENT

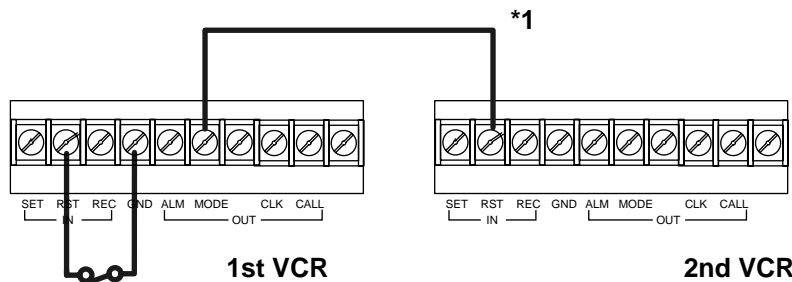

If the “ALARM REC DURATION” of the “RECORDING SET UP” menu is set to other than “MAN1”, the on-screen clock can be reset to the nearest hour, by applying a signal to the RST (RESET) IN terminal. For example, if the current time is 11:29:59, it will be reset to 11:00:00; and if the current time is 11:30:00, it will be reset to 12:00:00.

*1: When connecting the MODE terminal of the 1st VCR with RST (RESET) IN terminal of the 2nd VCR and if the “MODE OUT” of the “REAR TERMINAL” menu is set to “CLOCK ADJ”, the on-screen clock of the 2nd VCR will automatically be adjusted to that of the 1st VCR.

ALARM RECORDING

SETTING FOR ALARM RECORDING

Alarm Recording is used to activate more rapid recording when the VCR is recording in one of the Time Lapse modes. Alarm Recording provides for more pictures during the Alarm duration. Emergency Recording enables Alarm Recording even if the VCR is off, stopped or in Timer Recording/Standby. You should set the Alarm Recording mode with the "RECORDING SET UP" menu before Alarm Recording is used.

1 Press the DISPLAY button to display MAIN MENU on the monitor.

```
<MAIN MENU>
DISPLAY
TIME DATE SEARCH
TIMER PROGRAM
▷ RECORDING SET UP
REAR TERMINAL
MAINTENANCE
FIRST TIME SET UP
Use JOG to select,
and ENTER.
Press DISPLAY to exit.
```

2 Turn the JOG dial to select "RECORDING SET UP" and turn the SHUTTLE ring to the right.

- "RECORDING SET UP" menu will appear.

3 Turn the JOG dial to select "ALARM REC MODE" and turn the SHUTTLE ring to the right.

```
<RECORDING SET UP>
▷ ALARM REC MODE          3H
ALARM REC DURATION       1M
EMERGENCY REC            OFF
```

4 Turn the JOG dial to set the alarm recording mode and turn the SHUTTLE ring to the right.

5 Turn the JOG dial to select "ALARM REC DURATION" and turn the SHUTTLE ring to the right.

```
<RECORDING SET UP>
ALARM REC MODE           3H
▷ ALARM REC DURATION     1M
EMERGENCY REC            OFF
```

6 Turn the JOG dial to set the alarm recording duration from 15 seconds to 10 minutes, MAN1 or MAN2(manual). Turn the SHUTTLE ring to the right.

- If the "ALARM REC DURATION" is set to "MAN1", alarm recording will continue until a signal is applied to the RST (RESET) IN terminal. If the signal applied to the RST (RESET) IN terminal is within the first 15 seconds of alarm recording, alarm recording will continue for 15 seconds then stop.
- If the "ALARM REC DURATION" is set to "MAN2", alarm recording will continue until the signal applied to the SET IN terminal is removed. If the signal applied to the SET IN terminal is removed within 15 seconds of the start of alarm recording, alarm recording will continue for 15 seconds then stop.
- The internal time clock can be adjusted if a signal is applied to the RST (RESET) IN terminal on the rear panel when the ALARM REC DURATION is set to other than "MAN1".

7 Turn the JOG dial to select "EMERGENCY RECORDING" and turn the SHUTTLE ring to the right.

- Turn the JOG dial to select "ON".

```
<RECORDING SET UP>
ALARM REC MODE           3H
ALARM REC DURATION       1M
▷ EMERGENCY REC           ON
```

8 Press the DISPLAY button.
The present time display will appear.

- During alarm recording, the alarm recording count will automatically be displayed except when DISPLAY mode "4" is selected.
 - The alarm recording count display counts up to 9999 alarm recordings and then it is reset to 0000 and continues counting.
 - When initializing the alarm recording list, the alarm recording count display will be reset.
 - The alarm indicator flashes during alarm recording and lights up when the alarm recording is finished.
 - When the alarm recording is finished, the VCR resumes recording in the same record mode as before the alarm recording.
 - If any of the menus are being set, and a SET signal is applied to the SET IN terminal, alarm recording will begin and the menu being set will disappear off the screen.

NOTE:

- If a set signal is applied during alarm recording, a new alarm recording will start with the new set signal. Should one SET signal be applied within 15 seconds of another, the later SET signal will be ignored and a new alarm recording will not take place.
- Alarm recording will continue for the duration of time which has been set in the "ALARM REC DURATION" menu, even if a timer recording has reached its end time.
- Alarm recording stops when the end of the tape is reached.

EMERGENCY RECORDING

Emergency Alarm Recording can start recording when an Alarm is triggered even if the VCR is off, stopped or in Timer Recording/Standby. Turn the JOG dial to select "EMERGENCY RECORDING" and turn the SHUTTLE ring to the right.

Turn the JOG dial to select "ON" to select to select Emergency Recording, or "OFF" to disable it.

- "EMGCY" lights up on the fluorescent display when the "EMERGENCY REC" of the "RECORDING SET UP" menu is set to "ON".

ALARM RECORD TIME DISPLAY

When alarm recordings begin, the start times are stored in memory, so it is possible to confirm when they have occurred. Select the "ALARM LIST" in the "MAINTENANCE" menu and the alarm list display will appear on the screen.

```

<ALARM LIST>
0001 05 - 01 - 98 01 : 00
0002 07 - 01 - 98 21 : 10
0003 10 - 01 - 98 09 : 15
    
```

- Up to 3 alarm recording start times can be stored in memory. For more than that, the first and the last 2 times will be displayed.
- The alarm recording list is reset by the following procedure.
 1. Select the "ALARM LIST CLEAR" in the "MAINTENANCE" menu.
 2. Turn the SHUTTLE ring to the right. "ALARM LIST CLEAR" will be displayed.
 3. Turn the SHUTTLE ring to the left. "ALARM LIST" will be cleared.

LOCATING THE START OF ALARM RECORDINGS

This machine automatically inserts an index signal at the beginning of each ALARM RECORDING, allowing the start of each alarm to be located.

■ INDEX SEARCH

During fast forward or rewind the machine will search for index signals. When an Index signal is found, the VCR will playback the tape and stay in still mode.

- 1 Press the COUNTER MEMORY/SKIP/INDEX button to illuminate "INDEX" on the fluorescent display. (On the fluorescent display "INDEX" will be illuminated and the number indication will be illuminated.)
- 2 Turn the JOG dial to display the number (1-15) corresponding to the alarm index you desire to locate.
- 3 Turn the SHUTTLE ring to the right (forward direction) or left (reverse direction). (The program indication number will decrease one by one as each index signal goes by.)

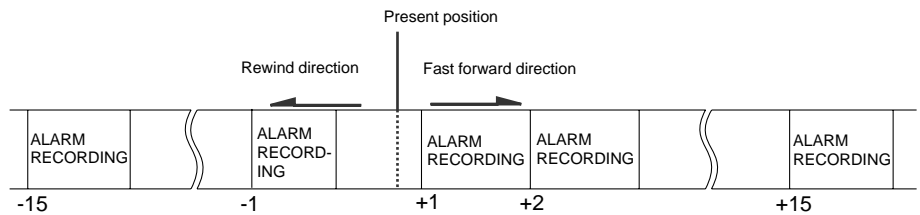

- The index signal may be difficult to locate in some recording conditions.

■ SKIP SEARCH

The VCR will fast forward or rewind until an index signal is located and then playback for about 4 seconds in 3H or 6H mode. This process is repeated until the end or beginning of the tape is reached.

- 1 Press the COUNTER MEMORY/SKIP/INDEX button to illuminate "SKIP" on the fluorescent display.
- 2 Turn the SHUTTLE ring to the right or left.

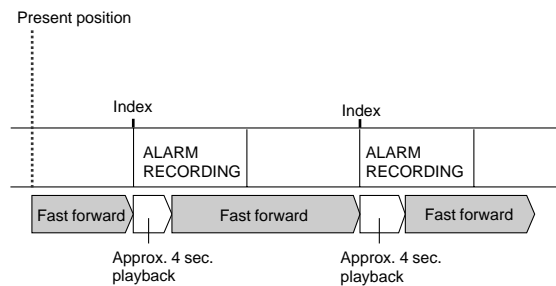

Until the index signal is located, the machine will fast forward (or rewind). When an index signal is located, the machine will playback (in 3H or 6H mode) for about 4 seconds. This process will be repeated until the end or the beginning of the tape is reached.

- When the desired position is located, press the PLAY button.
- To stop SKIP SEARCH, press the STOP button.
- The index signal may be difficult to locate in some recording conditions.

PLAYBACK

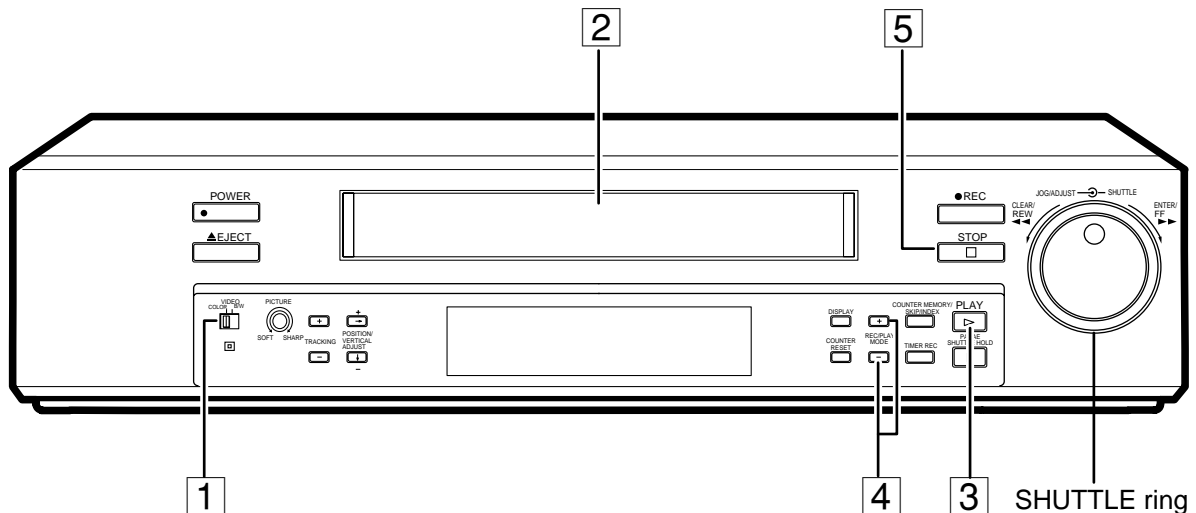

- 1 Set the VIDEO to either COLOR or B/W. When B/W is set, color recordings are played without color.
- 2 Load a pre-recorded tape.
AUTO PLAY:
 If a cassette with the erasure prevention tab removed is loaded, the unit automatically begins playback mode.
- 3 Press the PLAY button to start playback.
- 4 Press the REC/PLAY MODE (+) or (-) button to select the desired playback mode.
 - A tape recorded in SP mode can not be played back in 6H and L18H mode.
 - A tape recorded in LP mode can not be played back in 3H and L24H mode.
- 5 Press the STOP button to stop playback.
 - Turn the SHUTTLE ring to the left to rewind the tape when the VCR is in the stop mode.
 - Turn the SHUTTLE ring to the right to fast forward the tape when the VCR is in the stop mode.

PLAYBACK MODE

- When the REC/PLAY MODE button is pressed, the playback mode is switched in the order of 3H → L24H → 24H → 48H → 72H → 96H → 120H → 168H → 0H → 3H → (in case of the recording in SP mode).
- When the REC/PLAY MODE button is pressed, the playback mode is switched in the order of 6H → L18H → 48H → 72H → 96H → 120H → 168H → 0H → 6H → (in case of the recording in LP mode).

AUDIO PLAYBACK

- The modes with the letter "L" (L18H or L24H) are for audio recording and playback on the linear track.

Playback mode	3H	6H	L18H	L24H	24H - 168H
Audio playback	Available	Available	Available	Available	Not Available
Picture quality	Good	Good	Vibrating	Vibrating	Less Vibrating

NOTE:

- There is normal sound playback only when a tape recorded in 3H - L24H modes is played back in its respective mode.
- If a recording is played back in a higher mode than it was recorded, the picture will be played back in slow motion, and if a recording is played back in a lower mode than it was recorded, the picture will be played back in fast motion.
- The picture may move up/down or noise may occur when the tape is played back in L18H, L24H, 24H - 168H mode (even if the tape was recorded in L18H, L24H, 48H - 168H mode).
- During the playback of a tape recorded in LP mode, the colour might not appear on the top edge of the screen.

When the end of the tape is reached.

The following functions are automatically engaged when tape end is reached during playback or fast forwarding.

Tape End Selected	"REPEAT" or "ALARM • PROT"	"STOP" or "REWIND"
Playback	The tape automatically rewinds to the beginning and stops.	Stop
Fast forward	Stop	Stop

SPECIAL EFFECTS PLAYBACK

The following convenient functions are available. Audio output is muted during special effects playback.

SHUTTLE RING

You can adjust the speed by using the SHUTTLE ring.

- 1 Press the PLAY button to begin playback.
- 2 Press the PAUSE/SHUTTLE HOLD button to obtain a still picture.
- 3 Turn the SHUTTLE ring to the angle for the desired playback speed.

NOTE:

- If the SHUTTLE ring is released, it will come back to the centre position and still mode will be resumed.
- Pressing the PAUSE/SHUTTLE HOLD button while turning and holding the SHUTTLE ring as in step 3, continues the playback speed you selected even though the SHUTTLE ring is released.
- If a tape recorded in LP mode is played back and the playback mode is shifted between any of the special effects playback modes, the colour might disappear.
- When a tape recorded in LP mode is in still or slow playback mode, the colour might not appear on the top edge of the screen.

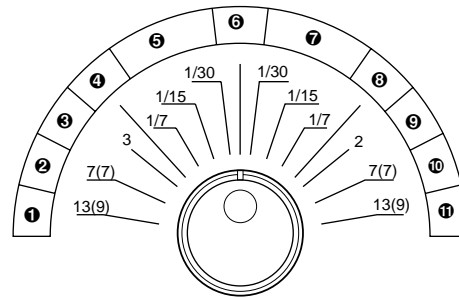

- | | |
|------------------------------|------------------------------|
| 1 Reverse high speed search | 7 Slow playback |
| 2 Reverse speed search | 8 Normal playback |
| 3 Reverse fast playback (x3) | 9 Fast playback (x2) |
| 4 Reverse playback | 10 Forward speed search |
| 5 Reverse slow | 11 Forward high speed search |
| 6 Still | |

() indicates the playback speed of the recorded tape in SP mode.

DIRECT SHUTTLE RING

You can also change the playback speed without entering the PAUSE mode by turning the SHUTTLE ring during playback.

If you release the ring, it will come back to the centre position, and normal playback will resume.

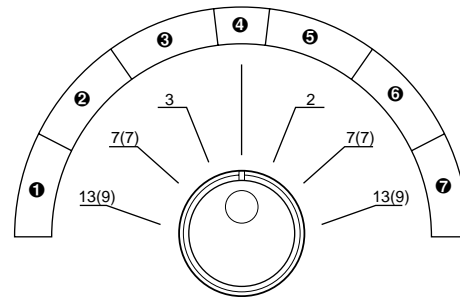

- | | |
|------------------------------|-----------------------------|
| 1 Reverse high speed search | 5 Fast playback (x2) |
| 2 Reverse speed search | 6 Forward speed search |
| 3 Reverse fast playback (x3) | 7 Forward high speed search |
| 4 Normal playback | |

() indicates the playback speed of the recorded tape in SP mode.

STILL PICTURE

If you press the PAUSE/SHUTTLE HOLD button during playback, you will obtain a still picture.

Press the PAUSE/SHUTTLE HOLD button again to resume the normal playback mode.

NOTE:

- A few noise bars or vertical movement may appear during still playback.
- When a tape recorded in LP mode is in still mode, the colour might not appear on the top edge of the screen.

FRAME BY FRAME PLAYBACK

You can use the JOG dial to advance the tape frame by frame.

- 1 While the VCR is playing a tape, press the PAUSE/SHUTTLE HOLD button to freeze the picture on screen.
- 2 Slightly rotate the JOG dial clockwise to advance the tape forward. Slightly rotate it counterclockwise to reverse the tape. To obtain a frame by frame picture continuously, keep rotating the JOG dial.
- 3 To resume normal playback, press the PLAY button.

NOTE:

- When switching between forward and reverse playback, noise bars may appear on the picture.
- A few noise bars or vertical movement may appear during frame by frame playback.

ADJUSTMENT DURING PLAYBACK

TRACKING ADJUSTMENT

If noise appears in the picture during playback, fast playback, reverse playback or forward/reverse slow playback, adjust the TRACKING buttons to achieve the best picture.

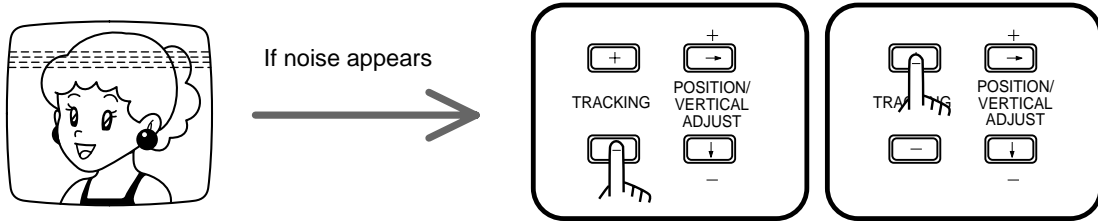

For tracking adjustment at fast playback, reverse playback or forward/reverse slow playback mode, press the PAUSE/SHUTTLE HOLD button while turning and holding the SHUTTLE ring.

When pressing the TRACKING (+) and (-) buttons at the same time during playback, reverse playback or forward/reverse slow playback, the tracking is set to the initial setting.

NOTE:

- When in reverse playback or reverse slow mode, noise bars may appear on the screen.
- Noise bars will move continuously through the picture when a TRACKING button is pressed and held (except in L24H playback mode).
- Noise bars will move through the picture each time the TRACKING button is pressed (in L24H playback mode).
- When a picture recorded in 3H mode is played back in L24H mode, noise may appear on the screen even though adjusted with the tracking button.

PICTURE QUALITY ADJUSTMENT

This control allows you to adjust the playback picture so that the outline is sharper or softer.

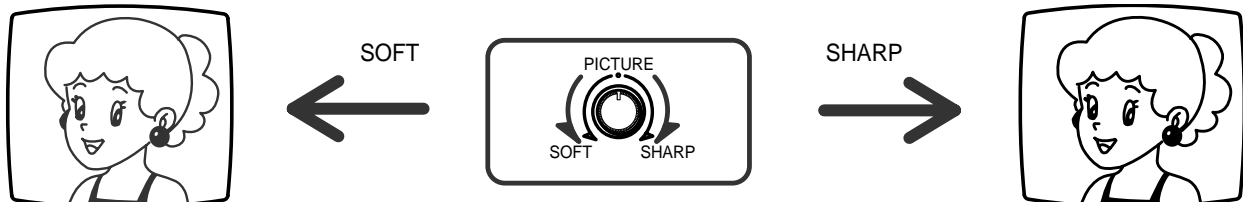

NOTE:

- This control is only effective during playback.

VERTICAL ADJUSTMENT (Correcting picture vibration at the top and bottom)

The picture vibration can be reduced or eliminated by the following steps.

- 1 If the vibration occurs in still, slow motion, fast playback(x2) or normal playback in 24H - 168H or 0H mode, playback a tape which is recorded in 3H or 6H mode with this VCR and press the PAUSE button.
If the vibration occurs during normal playback in L18H or L24H mode, playback a tape in each playback mode.
- 2 Press the VERTICAL ADJUST (+) or (-) button to reduce or eliminate the picture vibration.

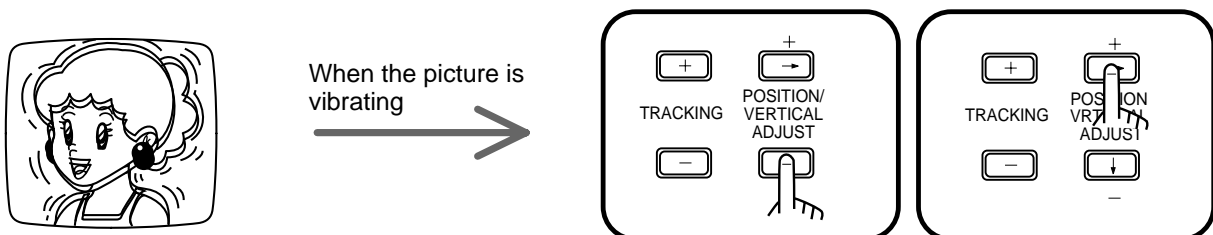

NOTE:

- Horizontal vibration cannot be corrected with the VERTICAL ADJUST buttons.
- When the VERTICAL ADJUST (+) and (-) buttons are pressed at the same time during still playback, the VERTICAL ADJUST is set to initial setting.

WARNING DISPLAY

SELF DIAGNOSTIC FUNCTION

The VCR uses a self diagnostic function to detect internal malfunctions during recording. Should a malfunction occur during recording, a corresponding indication appears on the monitor screen and the fluorescent display.

The type of malfunction corresponding to the indication, and countermeasures, are given below.

Fluorescent display	Monitor	CAUSE	REMEDY	TO TURN OFF THE INDICATION
End	TAPE END	THE TAPE ENDS DURING RECORDING	Rewind the tape and press the EJECT button.	Turn off the indication on the fluorescent display and on the screen by pressing the EJECT button or rewinding the tape.
—	NO SIGNAL	LACK OF VIDEO SIGNAL INPUT (NOTE 1)	Check for loose connections.	When a video signal is restored or the record mode is cleared, the indication on the screen turns off.
—	CHECK	TAPE/DECK TROUBLE	First, check the cassette. If there seems to be nothing wrong with the cassette, try the recording operation again. If the indication "CHECK" is still displayed, change the cassette with a new one and try the operation again. Otherwise, unplug the power cord and contact your dealer.	

NOTE:

1. Lack of video input signal.

If the VCR is set to record and an input signal is not detected, the indication NO SIGNAL appears on the monitor screen and the CALL signal is output from the rear terminal.

Check that the cable from the camera is not broken and the camera's power has not been lost.

BEFORE CALLING FOR SERVICE

Symptom	Remedy
VCR does not operate.	<ul style="list-style-type: none"> • Is the LOCK indicator illuminated? • Has the power cord been disconnected from the AC outlet? • Is the TIMER REC indicator illuminated?
The VCR POWER is ON but unit does not operate.	<ul style="list-style-type: none"> • Is the LOCK indicator illuminated? • Safety devices are operating. Press the RESET button on the rear panel using a suitable implement.
No picture is obtained on the MONITOR screen.	<ul style="list-style-type: none"> • Is the video cable connected properly, or is the cable defective?
No operation when any tape operation button is pressed.	<ul style="list-style-type: none"> • Is the LOCK indicator illuminated? • Is a cassette inserted?
Recording does not work.	<ul style="list-style-type: none"> • Is the LOCK indicator illuminated? • Has the cassette's erasure prevention tab been broken off? • Has the tape run out?
Recording cannot be stopped by pressing the STOP button.	<ul style="list-style-type: none"> • Is the LOCK indicator illuminated? • Is the TIMER REC indicator illuminated?
Timer recording does not operate.	<ul style="list-style-type: none"> • Has the present time and recording time been set accurately?
No operation when the PLAY button is pressed.	<ul style="list-style-type: none"> • Is the LOCK indicator illuminated? • Has the tape run out? • Is a cassette inserted?
Noise bars in the picture during playback.	<ul style="list-style-type: none"> • Has the TRACKING control been adjusted?
The picture vibrates at the top and bottom when in still picture mode.	<ul style="list-style-type: none"> • Has the VERTICAL ADJUST control been adjusted?
Clear camera pictures during recording but during playback the picture is not clear.	<ul style="list-style-type: none"> • This symptom may occur when the recorder has been used for a long period of time. During this time, a deposit of oxide has built up on the video heads which must now be cleaned. Cleaning of the heads requires expertise. Please consult your dealer.
The picture is not clear on the monitor.	<ul style="list-style-type: none"> • Is the camera focused?
The present time is not correct even though the VCR is used everyday.	<ul style="list-style-type: none"> • Make sure the VCR has mains power supplied continuously for at least 40 hours per week.
The power cord has been disconnected for less than 31 days but the present time has been reset.	<ul style="list-style-type: none"> • Make sure the VCR has mains power supplied continuously for at least 40 hours per week. • The contents stored in the memory may be erased before the 31 days depending on the charge time of the power failure compensation circuit. Set the present time again.
Repeat recording does not work.	<ul style="list-style-type: none"> • Is the repeat recording indicator illuminated? • Is the alarm recording started?
Alarm recording does not work.	<ul style="list-style-type: none"> • Is the external switch connected correctly?
Playback speed is fast or slow.	<ul style="list-style-type: none"> • Is the playback mode set to the desired mode with REC/PLAY MODE button?

CONTROL INPUT/OUTPUT SIGNALS AND CIRCUITS

■ SET/ RST/ REC IN terminals (screw)

Active: When input terminals are short-circuited to GND or "L" level voltage (0 - +1.6V) applied.
 Time for active: 0.1 sec or over.
 Non active: Open the input.

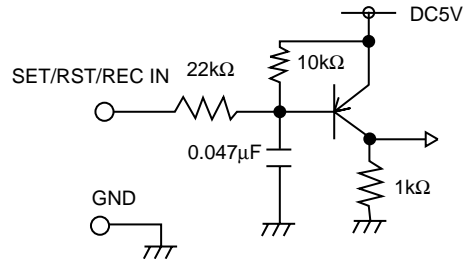

<Interface circuit inside the VCR>

■ ALM/ MODE/CALL OUT terminals (screw)

Active: "L" Level voltage (0 - +0.4V) outputted; max. drive current 50mA(+5V DC)/ 10mA(+24V DC)
 Non active: Open; max. voltage +24V DC

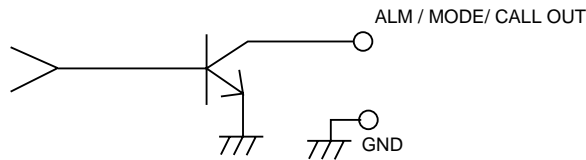

<Interface circuit inside the VCR>

■ CLK OUT terminal (screw)

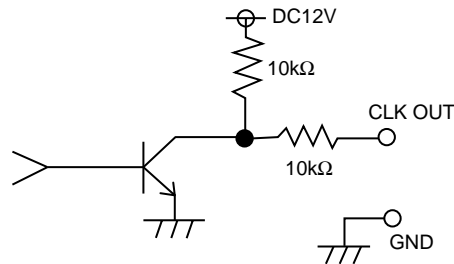

<Interface circuit inside the VCR>

CLK OUT signal

- When "F" is selected in REC of CLOCK OUT mode in 3H or 6H recording.

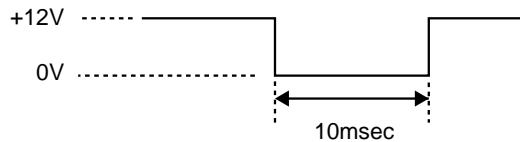

- During recording in L18H - 168H recording mode.

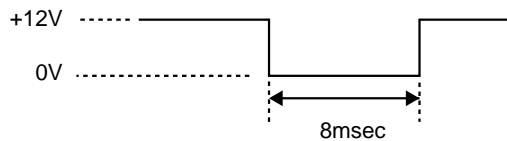

- When except "F" is selected in REC of CLOCK OUT mode in 3H or 6H recording.

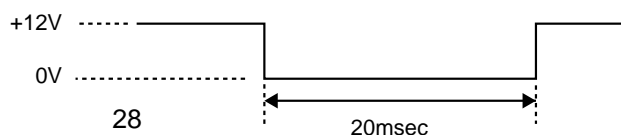

CONTROL INPUT/OUTPUT SIGNALS AND CIRCUITS

■ REMOTE jack

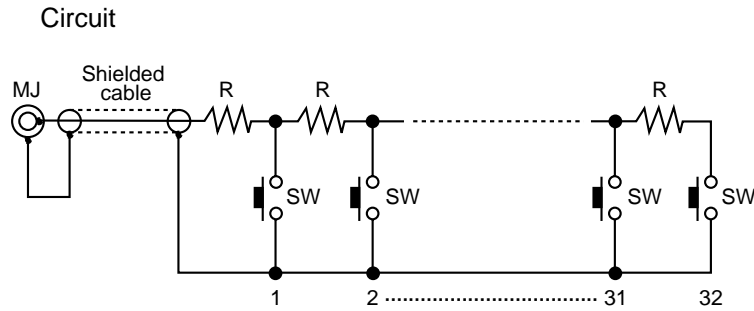

- 1) Resistor R: Metal film resistor 1/4W 33kohms $\pm 1\%$, temperature factor $\pm 100\text{ppm}/^\circ\text{C}$.
- 2) Button switch: Momentary, ON resistor 200ohms or under.
- 3) Connector MJ: Miniature jack, 2.5mm in diameter, comply with JISC6560.

Operational conditions

- 1) Isolation resistor: 200Mohms or over (in connector MJ)
- 2) Floating capacity: 0.1 μF or under (in connector MJ).
- 3) Environmental temperature: 5-40 $^\circ\text{C}$ (common with VCR).
- 4) Relative temperature: Max. 80% (common with VCR).

Remote control switch functions

Position	Function	Position	Function	Position	Function	Position	Function
1	STOP	9	3H/6H	17	POWER ON/OFF	25	DOWN POSITION/SHIFT
2	RECORDING	10	L24H/L18H	18	REVERSE FRAME SHIFT	26	UP POSITION/SHIFT
3	PAUSE	11	48H (SP/LP)	19	TIME DATE SEARCH	27	CLEAR
4	PLAYBACK	12	72H (SP/LP)	20	INDEX SEARCH	28	START/END
5	REVERSE PLAYBACK	13	120H (SP/LP)	21	(-)DISPLAY/SET	29	(-)REC/PLAY MODE
6	FORWARD FRAME SHIFT	14	168H (SP/LP)	22	(+)DISPLAY/SET	30	(+)REC/PLAY MODE
7	FAST FORWARD	15	0H (SP/LP)	23	LEFT POSITION/SHIFT	31	SKIP SEARCH
8	REWIND	16	SP/LP	24	RIGHT POSITION/SHIFT	32	TIMER RECORDING

■ Remote control unit (optional)

The optional Remote Control (R-7100) provides remote operation of the VCR. Before using the remote control, put the label on it as shown in Fig.

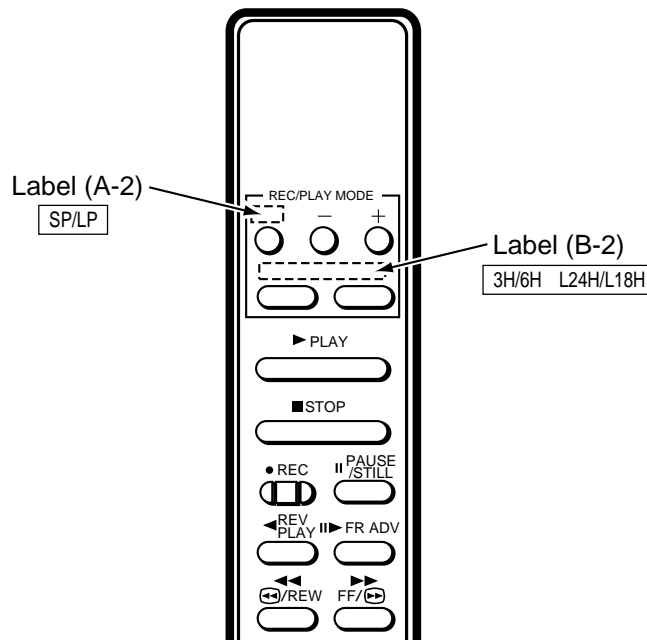

SPECIFICATIONS

Tape Format:	VHS 1/2" width high-density video cassette tape.						
Power Source:	AC100-230V (HS-7168E(B), HS-7168EM(B)), AC100-240V (HS-7168E(A)), 50/60Hz.						
Power Consumption:	Approx.20watts.						
Television System:	625 lines, 50 field PAL-type color system.						
Video Recording System:	2 rotary heads, azimuth helical scanning system.						
Luminance Signal:	Frequency modulation recording.						
Color Signal:	Low frequency conversion, sub-carrier phase shift recording.						
Audio Track:	1 track.						
Tape Speed and Recording Time (with E-180 cassette):	Mode	Time	Speed	Recording interval	Video signal	Audio signal	Tape drive
	3H(SP)	3hrs	23.39mm/sec	20.00msec./Field	Continuous	Recordable	Continuous
	6H(LP)	6hrs	11.70mm/sec	20.00msec./Field	Continuous	Recordable	Continuous
	L18H(LP)	18hrs	3.90mm/sec	60.00msec./Field	Time lapse	Recordable	Continuous (Slow)
	L24H(SP)	27hrs	2.60mm/sec	180.00msec./Field	Time lapse	Recordable	Continuous (Slow)
	48H(SP)	51hrs	–	340msec./Field	Time lapse	Not recorded	Time lapse
	48H(LP)	54hrs	–	180msec./Field	Time lapse	Not recorded	Time lapse
	72H(SP)	75hrs	–	500msec./Field	Time lapse	Not recorded	Time lapse
	72H(LP)	78hrs	–	260msec./Field	Time lapse	Not recorded	Time lapse
	96H(SP)	99hrs	–	660msec./Field	Time lapse	Not recorded	Time lapse
	96H(LP)	102hrs	–	340msec./Field	Time lapse	Not recorded	Time lapse
	120H(SP)	123hrs	–	820msec./Field	Time lapse	Not recorded	Time lapse
	120H(LP)	126hrs	–	420msec./Field	Time lapse	Not recorded	Time lapse
	168H(SP)	171hrs	–	1140msec./Field	Time lapse	Not recorded	Time lapse
	168H(LP)	174hrs	–	580msec./Field	Time lapse	Not recorded	Time lapse
	0H	–	–	–	Time lapse	Not recorded	Time lapse
Fast Forward/Rewind Time:	Approx. 140sec. with E-180 cassette.						
Video Heads:	6 rotary single crystal heads.						
Audio/Control:	1 stationary head.						
Erase:	1 full-track head.						
Motors:	3 motors-drum/capstan direct drive system.						
Video Input:	1.0Vp-p, 75ohms BNC plug.						
Audio Input:	-8dBs, 50kohms, RCA plug.						
Microphone Input:	-67dBs, 600ohms, mini mic jack.						
Video Output:	1.0Vp-p, 75ohms BNC plug.						
Audio Output:	-6dBs, 1kohms, RCA plug.						
Horizontal Resolution:	More than 330 lines (Black & White)						
	More than 240 lines (Colour)						
Audio Frequency Response:	70Hz- 7kHz (3H mode).						
Signal-to-Noise Ratio:	Video: better than 42dB.						
	Audio: better than 43dB.						
Operating Temperature:	41°F-104°F (5°C to 40°C).						
Relative Humidity:	Max.80(%)						
Dimensions:	16.7(W)x12.4(D)x3.7(H)(in.).						
(Jog dial included)	425(W)x315(D)x93(H)(mm).						
Weight:	10 lbs (4.5kg.)						
Alarm Recording Time:	Timed: 15 sec/30 sec/45 sec/1 min./2 min./5 min./10 min.						
	Manual 1: Until the alarm reset switch is switched on. Manual 2: Until the alarm set switch is switched off.						
Display Format:	DISPLAY MODE 1: (Day)-(Month)-(Year) (Hour) : (Minute) : (Second) (Alarm recording no.)						
	DISPLAY MODE 2: (Day)-(Month)-(Year) (Day of week) (Alarm recording no.), (Hour) : (Minute) : (Second) (Recording mode)						
Display Position:	In any position.						
Timer Program:	8 programs - daily start and stop time for one week.						
Memory Backup:	Lasts 31 days.						
Elapsed Time Indicator:	The maximum of 89,999 hours.						
CONNECTORS							
SET Input:	Screw terminal for starting alarm recording.						
RST Input:	Screw terminal for finishing alarm recording or for adjusting on-screen clock.						
REC Input:	Screw terminal for starting/finishing recording or for series recording or for synchronous recording.						
GND:	Screw terminal for ground.						
ALM Output:	Screw terminal for output while alarm recording is under way.						
CLK Output:	Screw terminal to command camera switching.						
MODE Output:	Screw terminal for indication of VCR selected mode.						
CALL Output:	Screw terminal for external warning device or for series recording.						
REMOTE Jack:	Jack for connecting the remote control unit.						
Rating:							
ALM/CALL/MODE	Active: "Low" level, max. Current 50mA (+5VDC)/10mA (+24VDC).						
	Non active: Open, max. Voltage +24V DC.						
SET/RST/REC	Active: When terminals are short-circuited or "Low" level voltage applied.						
	Non active: Open, max. Voltage +17V DC.						
CLK	Recording: A pulse of the frequency division ratio selected by REAR TERMINAL menu.						

Weight and dimensions shown are approximate.
Design and specifications are subject to change without notice.

