



---

# HDD Extension Unit

## INSTALLATION AND OPERATION MANUAL

---

MODEL

# DX-ZD5UE(Z)

ENGLISH

DEUTSCH

FRANÇAIS

ESPAÑOL

РУССКИЙ

ITALIANO

NEDERLANDS



THIS INSTRUCTION MANUAL IS IMPORTANT TO YOU. PLEASE READ IT BEFORE USING YOUR HDD EXTENSION UNIT.

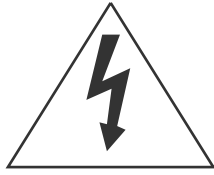

## WARNING

RISK OF ELECTRIC SHOCK  
DO NOT OPEN



**WARNING:** TO REDUCE THE RISK OF ELECTRIC SHOCK,  
DO NOT REMOVE COVER (OR BACK)  
NO USER-SERVICEABLE PARTS INSIDE  
REFER SERVICING TO QUALIFIED SERVICE PERSONNEL.

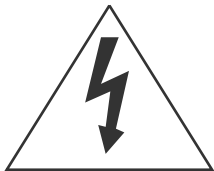

The lightning flash with arrowhead symbol, within an equilateral triangle, is intended to alert the user to the presence of uninsulated “dangerous voltage” within the product’s enclosure that may be of sufficient magnitude to constitute a risk of electric shock.



The exclamation point within an equilateral triangle is intended to alert the user to the presence of important operating and maintenance (servicing) instructions in the literature accompanying the appliance.

## WARNING:

TO PREVENT FIRE OR SHOCK HAZARD, DO NOT EXPOSE THIS APPLIANCE TO RAIN OR MOISTURE.

## CAUTION:

TO PREVENT ELECTRIC SHOCK DO NOT USE THIS (POLARIZED) PLUG WITH AN EXTENSION CORD, RECEPTACLE OR OTHER OUTLET UNLESS THE BLADES CAN BE FULLY INSERTED TO PREVENT BLADE EXPOSURE.

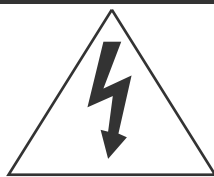

## AVERTISSEMENT

DANGER D'ÉLECTROCUTION  
NE PAS OUVRIR



**AVERTISSEMENT:** POUR ÉLIMINER TOUT RISQUE D'ÉLECTROCUTION, NE PAS OUVRIR LE COUVERCLE (OU LA PARTIE ARRIÈRE). AUCUNE PIÈCE RÉPARABLE PAR L'UTILISATEUR NE SE TROUVE À L'INTÉRIEUR. POUR TOUTE INTERVENTION D'ENTRETIEN OU DE RÉPARATION SE CONFIER AUX TECHNICIENS QUALIFIÉS.

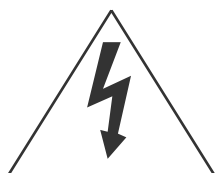

La flèche symbolisant l'éclair dans un triangle équilatéral a pour objet de tirer l'attention de l'utilisateur sur le fait, qu'il y a des "tensions dangereuses" non-isolées à l'intérieur de l'enceinte du produit qui peuvent être suffisamment importantes pour conduire au risque d'électrocution.



Le point d'exclamation au sein d'un triangle équilatéral a pour objet de tirer l'attention de l'utilisateur sur le fait qu'il y a des instructions de mise en service et d'entretien (de réparation) dans les fiches descriptives de l'appareil qui doivent obligatoirement être respectées.

## AVERTISSEMENT:

AFIN D'ÉVITER TOUT RISQUE D'INCENDIE OU D'ÉLECTROCUTION, NE PAS EXPOSER CET APPAREIL À LA PLUIE NI À L'HUMIDITÉ.

## ATTENTION:

POUR PRÉVENIR LES CHOCS ÉLECTRIQUES NE PAS UTILISER CETTE FICHE POLARISÉE AVEC UN PROLONGATEUR, UNE PRISE DE COURANT OU UNE AUTRE SORTIE DE COURANT, SAUF SI LES LAMES PEUVENT ÊTRE INSÉRÉES À FOND SANS EN LAISSER AUCUNE PARTIE À DÉCOUVERT.

# Important safeguards

---

PLEASE READ ALL THESE INSTRUCTIONS REGARDING YOUR HDD EXTENSION UNIT AND RETAIN FOR FUTURE REFERENCE. FOLLOW ALL WARNINGS AND INSTRUCTIONS MARKED ON THE HDD EXTENSION UNIT.

## 1. Read Instructions

All the safety and operating instructions should be read before the appliance is operated.

## 2. Retain Instructions

The safety and operating instructions should be retained for future reference.

## 3. Heed Warnings

All warnings on the appliance and in the operating instructions should be adhered to.

## 4. Follow Instructions

All operating and use instructions should be followed.

## 5. Cleaning

Unplug this product from the wall outlet before cleaning. Do not use liquid or aerosol cleaners. Use a damp cloth for cleaning.

## 6. Attachments

Do not use attachments not recommended by the product manufacturer as they may cause hazards.

## 7. Water and Moisture

Do not use this product near water – for example, near a bath tub, wash bowl, kitchen sink, or laundry tub, in a wet basement, or near a swimming pool, and the like.

## 8. Accessories

Do not place the product on an unstable cart, stand, tripod, bracket, or table. The product may fall, causing serious injury. Any mounting of the appliance should follow the manufacturer's instructions, and should use a mounting accessory recommended by the manufacturer.

An appliance and cart combination should be moved with care. Quick stops, excessive force, and uneven surfaces may cause the appliance and cart combination to overturn.

## 9. Ventilation

Slots and openings in the cabinet are provided for ventilation and to ensure reliable operation of the product and to protect it from overheating, and these openings must not be blocked or covered. This product should never be placed near or over a radiator or heat register. This product should not be placed in a built-in installation such as a bookcase or rack unless proper ventilation is provided or the manufacturer's instructions have been adhered to.

## 10. Power Sources

This product should be operated only from the type of power source indicated on the marking label. For products intended to operate from battery power, other sources, refer to the operating instructions.

## 11. Grounding or Polarization

This product is equipped with a 3-wire grounding-type plug, a plug having a third (grounding) pin. This plug will only fit into a grounding-type power outlet. This is a safety feature. If you are unable to insert the plug into the outlet, contact your electrician to replace your obsolete outlet. Do not defeat the safety purpose of the grounding-type plug.

## 12. Power-Cord Protection

Power-supply cords should be routed so that they are not likely to be walked on or pinched by items placed upon or against them, paying particular attention to cord at plugs, convenience receptacles, and the point where they exit from the appliance.

## 13. Lightning

For added protection for this product receiver during a lightning storm, or when it is left unattended and unused for long periods of time, unplug it from the wall outlet. This will prevent damage to the product due to lightning and power-line surges.

## 14. Overloading

Do not overload wall outlets and extension cords as this can result in a risk of fire or electric shock.

## 15. Object and Liquid Entry

Never spill liquid of any kind on the product.



**16. Servicing**

Do not attempt to service this product yourself as opening or removing covers may expose you to dangerous voltage or other hazards. Refer all servicing to qualified service personnel.

**17. Damage requiring Service**

Unplug this product from the wall outlet and refer servicing to qualified service personnel under the following conditions:

- (a) When the power-supply cord or plug is damaged.
- (b) If liquid has been spilled, or objects have fallen into the product.
- (c) If the product has been exposed to rain or water.
- (d) If the product does not operate normally by following the operating instructions. Adjust only those controls that are covered by the operating instructions as an improper adjustment of other controls may result in damage and will often require extensive work by a qualified technician to restore the product to its normal operation.
- (e) If the product has been dropped or the cabinet has been damaged.
- (f) When the product exhibits a distinct change in performance, this indicates a need for service.

**18. Replacement Parts**

When replacement parts are required, be sure the service technician has used replacement parts specified by the manufacturer or have the same characteristics as the original part. Unauthorized substitutions may result in fire, electric shock or other hazards.

**19. Safety Check**

Upon completion of any service or repairs to this product, ask the service technician to perform safety checks to determine that the product is in safe operating conditions.

**20. Heat**

The product should be situated away from heat sources such as radiators, heat registers, stoves, or other products (including amplifiers) that produce heat.

**NOTE**

This equipment has been tested and found to comply with the limits for a Class A digital device, pursuant to Part 15 of the FCC Rules. These limits are designed to provide reasonable protection against harmful interference when the equipment is operated in a commercial environment. This equipment generates, uses, and can radiate radio frequency energy and, if not installed and used in accordance with the instruction manual, may cause harmful interference to radio communications. Operation of this equipment in a residential area is likely to cause harmful interference in which case the user will be required to correct the interference at his own expense. Changes or modifications not expressly approved by the party responsible for compliance could void the user's authority to operate the equipment.

**NOTE**

THIS CLASS A DIGITAL APPARATUS COMPLIES WITH CANADIAN ICES-003.

CET APPAREIL NUMÉRIQUE DE LA CLASSE A EST CONFORME À LA NORME NMB-003 DU CANADA.

# Caution and care

**HEAVY OBJECTS SHOULD NEVER BE PLACED ON THE UNIT (E.G., MONITOR)**

## **NEVER TOUCH OR INSERT ANY OBJECT INSIDE THE UNIT**

Touching the inside of the cabinet or inserting foreign objects of any kind through the ventilation holes not only creates a safety hazard but can also cause extensive damage.

## **PROTECT THE POWER CORD**

Damage to the power cord may cause fire or shock hazard. If the mains cord is damaged, turn OFF the MAIN switch and carefully unplug the cord by holding the mains plug.

If this unit is moved with the power on status, the HDDs may be damaged. Ensure that more than one minute have passed since the power cord and the connecting cords were disconnected, then move this unit.

## **UNPLUG THE POWER CORD DURING A LONG ABSENCE**

Turn off the power and unplug the power cord during a long absence.

## **MAINTAIN GOOD VENTILATION**

Do not obstruct the many ventilation holes on the unit. For maximum ventilation, leave some space around the unit and place the unit on a hard level surface only, and ensure it is not covered during use. Heavy objects should never be placed on the unit.

## **WHEN NOT IN USE**

When not in use, always turn OFF the MAIN switch.

## **CABINET CARE**

Never use petroleum-based cleaners. They may cause deterioration or coat flaking of the unit. Clean with a soft cloth moistened with soap and water and wipe dry.

When using chemical duster, follow the instructions.

## **INSTALLATION LOCATION**

For excellent performance and lasting reliability install in a location that is:-

1. Well ventilated, out of direct sunlight and away from direct heat.
2. A solid vibration-free surface.
3. Free from high humidity, excessive dust and away from magnetic fields.
4. Please ensure that the ventilation fan located on the unit's back panel is not blocked.

## **UNSUITABLE LOCATIONS**

Placing the unit in the following places might shorten the product life:

- Extremely cold places, such as refrigerated warehouses and ice houses
- Places where excessive hydrogen sulfide is likely to be generated, such as hot-springs areas
- Places or locations with salt air environment.

**NO OBJECTS FILLED WITH LIQUIDS, SUCH AS VASES, SHALL BE PLACED ON THE APPARATUS.**

**DO NOT PLACE HEAVY OBJECT ON THIS UNIT.**

**DO NOT STEP ONTO THIS UNIT.**

**WARNING: TO PREVENT FIRE OR SHOCK HAZARD, DO NOT EXPOSE THIS APPARATUS TO RAIN OR MOISTURE. THIS APPARATUS MUST BE GROUNDED.**

## **MAINS LEAD CONNECTION**

The mains lead on this Unit is fitted with a non-rewireable mains plug, incorporating a 5A fuse. If you need to replace the fuse, use a 5A fuse approved by BSI or ASTA to BS 1362, ensuring you refit the fuse cover. If the mains plug is not suitable for the sockets in your home, and you require to remove the plug, remove the fuse, cut off the plug then dispose of the plug immediately, to avoid a possible electric shock hazard. To refit a new plug, follow these instructions; Green-and-yellow: Earth, Blue: Neutral and Brown: Live. As the colours in the mains lead of this Unit may not correspond with the coloured markings identifying the terminals in your plug, proceed as follows.

- The wire which is coloured green-and-yellow must be connected to the terminal in the plug which is marked by the letter E or by the safety earth symbol  $\perp$  or coloured green or green-and-yellow.
- The wire which is coloured blue must be connected to the terminal which is marked with the letter N or coloured black.
- The wire which is coloured brown must be connected to the terminal which is marked with the letter L or coloured red.

This unit complies with the requirements of the EC Directive 89/336/EEC, "EMC Directive" and 73/23/EEC, "Low Voltage Directive", as amended by Directive 93/68/EEC. The requirements for the susceptibility according to EN 55024 and the requirements for interference according to EN 55022 (Class B) are observed for the operation on residential areas, business, light industrial premises and in small scale enterprises, inside as well as outside of the building. All places of operation are characterised by their connection to the public low voltage power supply system. This unit is manufactured in accordance with EN 60950.

**WARNING:**

The power cords for use in the U.S., the continent of Europe, and U.K. are included with this unit.

Use the appropriate one for your country.

The power cord for use in the U.S. is used for 120V only. Never connect to any outlet or power supply having a different voltage or frequency.

Before starting recording important images, make sure to perform trial recording to ensure that images are properly recorded. The user will not be indemnified for problems (e.g., recording failure or playback failure) that occur with either the unit or a connected device during operation. It is recommended that backups of important recordings are made regularly as a precaution against possible breakdowns and accidents.

- This unit uses a hard disk, which is a precision device. Please handle this unit with sufficient care.
- Do not subject this unit to vibrations or shocks. This may cause trouble specially when the power of the unit is turned on or when the hard disk is being accessed, and sufficient care is required.
- Do not disconnect the power plug or the USB cable while the power of the unit is turned on or while recording or playing.
- For early detection of faults, we recommend that you request inspection once a year.
- Do not move this unit at least one minute after the power is turned off.

The hard disk and cooling fan are not permanent items and will need replacement with time. When operated in an ambient temperature of 25 °C, it is recommended that both of the hard disk and fan are replaced every 30,000 hours. (This figure is only a guide, and should not be taken as a guaranteed lifespan of the products. Use the <Elapsed Operating Time> (System Menu → Service Info) of the DX-TL5000U/E as a guide to perform checkups.)

**INSTALLATION LOCATION AND HANDLING**

- Do not plug this unit into the same outlet which is being used for other large power consuming equipment such as a copying machine and air conditioner.
- Do not place this unit close to other equipment to prevent adverse interference between them.
- Do not place this unit close to strong magnetized objects. They may cause effects on the images or loss of recorded data.
- Never apply volatile substances such as insecticides and do not put rubber- or plastic-products on the unit for a long period. They may cause deterioration of this unit or flaking of the coating.
- Keep the allowable ambient temperature. When using this unit at a low temperature, turn on the power and wait for 10 minutes or more before use.

**WHEN MOVING THIS UNIT**

- When you move this unit, make sure to turn off the power and unplug. When a strong shock is applied to this unit while it is on, the electronic parts inside the unit may be damaged. Take care especially while the ACCESS indicator is illuminating.
- When you move this unit, wrap it with cushions to avoid shock to the internal parts.

**COPYRIGHT**

- This unit records images digitally. When recording copyrighted images, be careful not to infringe their copyrights.

**Disclaimer**

In any event, Mitsubishi assumes no responsibility or reliability for the following:

1. Disassembly, repair, or alteration of this unit by user or installer.
2. Failure or breakdown in or damage to this unit resulting from misuse or careless handling by user or installer.
3. Inconvenience or damages arising out of inability to display or record images due to any reason or cause other than breakdown or failure in this unit.
4. Failure in this unit due to combination with other equipment manufactured by a third party or inconvenience or damages resulting from such failure.
5. Inconvenience, damages, or claims arising out of breakdown in this unit or loss of recorded video data due to replacement of the HDD by user or installer.
6. Inconvenience or damages arising out of breakdown in this unit or inability to display or record images due to natural disaster including earthquake and storm.
7. Inconvenience, damages, or claims arising out of breakdown in this unit or loss of recorded video data due to impact or vibration to the HDD or an environmental factor such as temperature at the installation site.
8. Demand for damages or other claim of infringement of privacy if the images monitored or recorded by user become public or are used for any purpose other than surveillance for whatever reason.

# Contents

---

Important safeguards .....	i-iv
Caution and care .....	2-3
Contents .....	4
Major operations and their functions .....	5-6
Front view .....	5
Rear view .....	6
Connections .....	7 -13
1. Connectable recorders .....	7
2. Connection example .....	7
3. Startup .....	8
4. Setting .....	8-10
5. Attaching and removing the HDD .....	10-12
6. Troubleshooting .....	13
7. Maintenance .....	13
Recording time table .....	14-17
Specifications .....	18

## How to read this manual

### • Viewing displays

 (Refer to this information when operating):  
Reference information concerning operation

 (Caution required):  
Cautionary items concerning operation

# Major operations and their functions

## ■ Front view

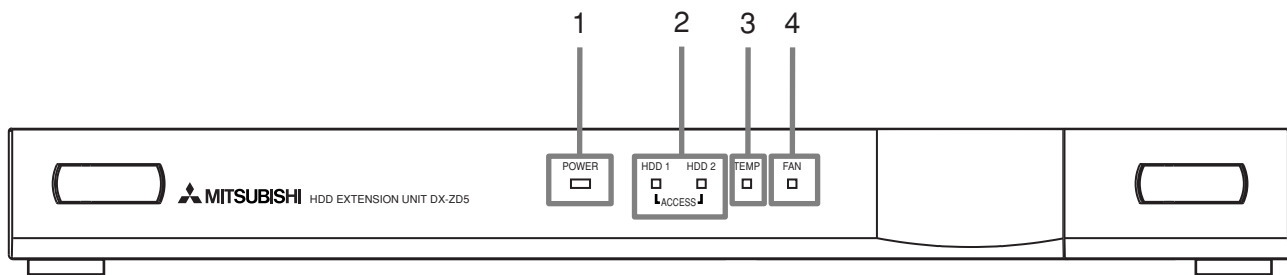

### 1. POWER indicator

When the EXTERNAL CONTROL switch is set to OFF, or it is set to ON with the connected recorder turned on, this indicator illuminates while the MAIN switch on the rear panel is turned on.

### 2. HDD indicators (ACCESS indicators)

Momentary flash during accessing HDD 1 or HDD 2.  
Flash during recording/copying data.

### 3. TEMP indicator

Illuminates when the internal temperature of this unit becomes high.

### 4. FAN indicator

Illuminates when the fan stops.

## ■ Rear view

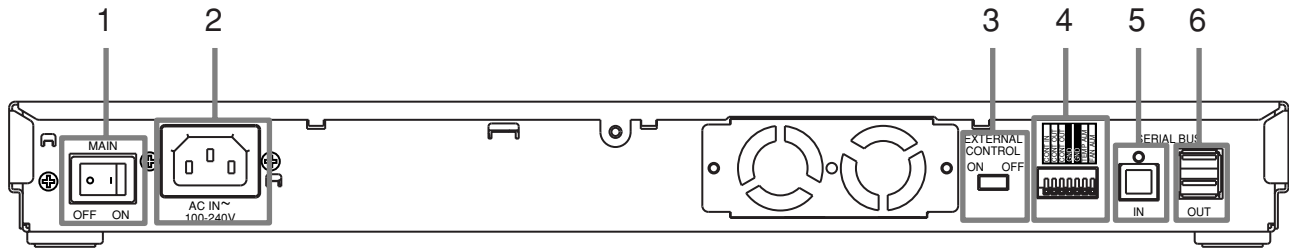

### 1. MAIN switch

This is the main power switch. When using this unit, set this switch to ON.

### 2. AC power socket

Used to connect the power cord. Earth terminal is used for safety. Use the 100 to 240 V plug with earth for the power of this unit.



- When the power outlet does not have an earth terminal, ask for your dealer of the earth work (pay service). Never connect the earth terminal on the power supply to a gas pipe, water pipe, conductor rod, and so on.
- Please use the supplied AC power cord.
- Make sure to plug this unit into the outlet of the same system which is being used for the recorder connected. When this unit is plugged into the outlet of other system, recording or copying after a power failure will not be carried out correctly.

### 3. EXTERNAL CONTROL switch

Set this switch to ON (left side) to turn on and off the power of this unit to link the recorder's switch. When not linking the recorder, set this switch to OFF (right side).



- When the EXTERNAL CONTROL switch is set to ON, make sure to connect the CONT IN terminal of this unit and DC 12V OUT terminal of the recorder, and the GND terminal of this unit and GND terminal of the recorder respectively. When the recorder is turned on, this unit is turned on linking with the recorder.
- It is recommended to use this unit linking with the recorder in order to give the internal hard disks a rest or a proper countermeasure is taken when a problem occurs on the recorder.

### 4. I/O terminals

#### CONT IN terminal

Terminal for inputting the power on/off status of the recorder. Connect this terminal with the DC 12V OUT terminal of the recorder.

#### CONT OUT terminal

Terminal for outputting the power on/off status of the recorder. When using multiple number of HDD extension unit and using the power on/off linkage function, connect this terminal with the CONT IN terminal of the unit to be connected.

#### GND terminals

They are the common GND terminals. When using the power on/off linkage function, connect this terminal with the GND terminal of the recorder.

#### TEMP ALM terminal

Terminal for informing the internal high temperature to the external device.

#### FAN ALM terminal

Terminal for informing abnormality of the fan.

### 5. SERIAL BUS input port

Port for connecting with the recorder.

### 6. SERIAL BUS output ports

Ports for connecting with another DX-ZD5UE(Z) when using multiple number of DX-ZD5UE(Z).



- It is impossible to supply 5V DC power from this port.



- Do not connect any devices other than DX-ZD5UE(Z) to these output ports.

## 1. Connectable recorders

MITSUBISHI DIGITAL RECORDER DX-TL5000U, DX-TL5000E

## 2. Connection example

- Connect this unit and a digital recorder by using the supplied USB cable.
- It is possible to connect some DX-ZD5UE(Z), as shown below.

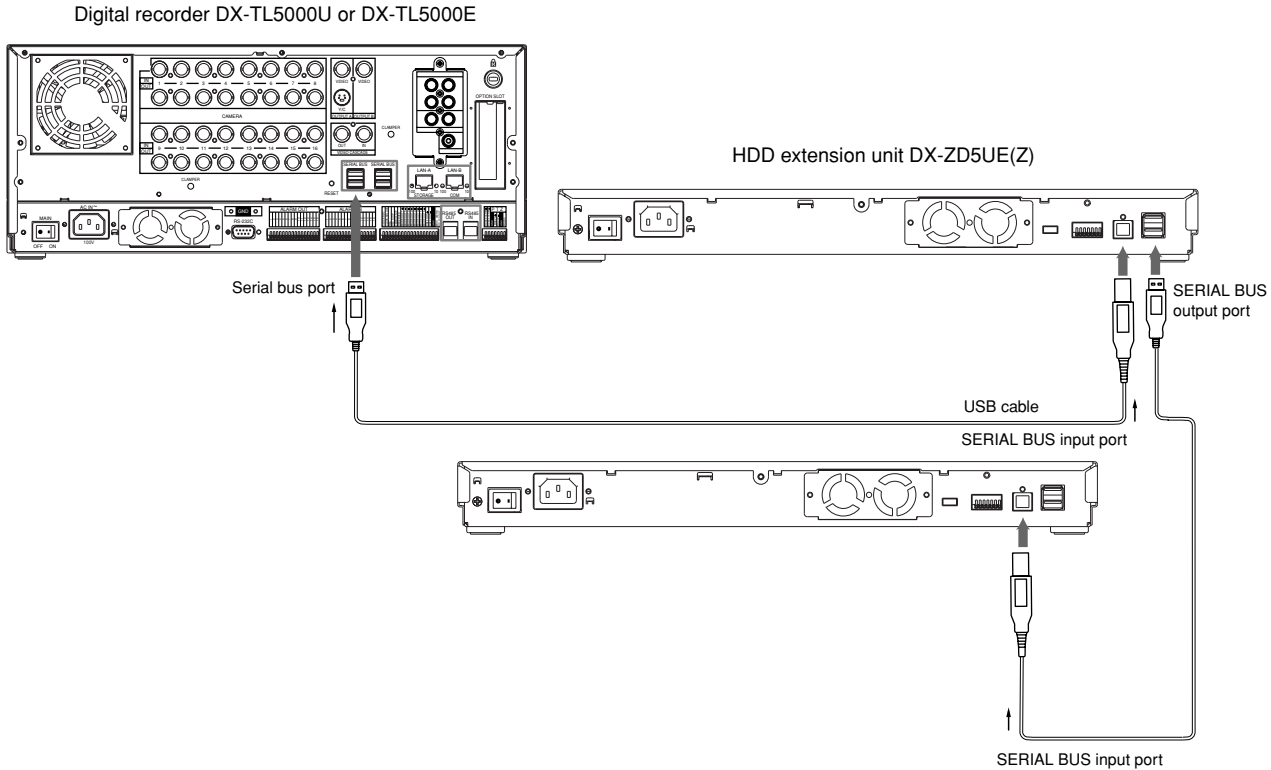

- The EXTERNAL CONTROL switch is set to ON at shipping. At this status, this unit does not work though you connect the power cord and set the MAIN switch to ON.

Connect this unit and the recorder as “Connection to link the power supply of the recorder and this unit” shown below.



- Up to 7 of HDD extension units can be used for one DX-TL5000U (or DX-TL5000E).
- It is not available to connect 5 or more HDD extension units in series.

### Connection to link the power supply of the recorder and this unit

- Set the EXTERNAL CONTROL switch to ON and connect the terminals as shown below. It is recommended to use this unit by linking the recorder’s power supply.
- To resume recording or copying after a power failure during normal recording or timer recording, plug this unit into the outlet of the same system which is being used for the recorder connected.

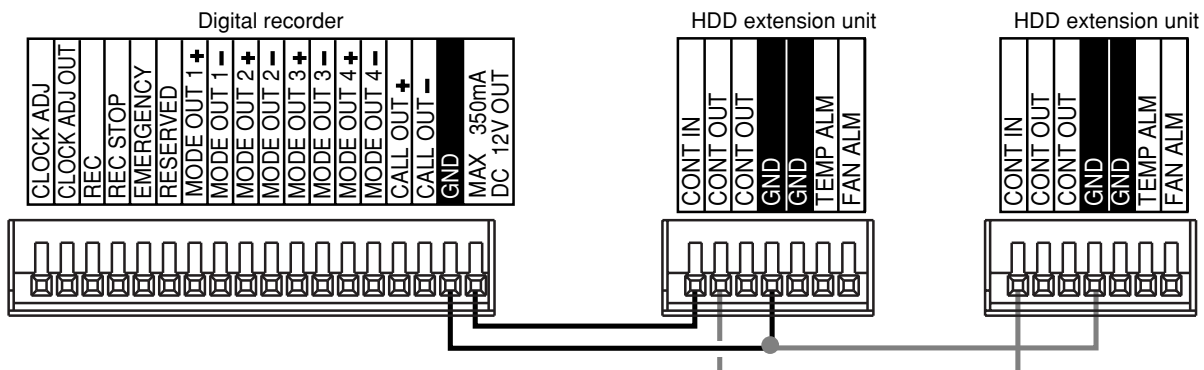

## 3. Startup

- step1. Turn on the power of this unit.
- step2. Turn on the main switch of the recorder.  
The POWER indicator of this unit illuminates.
- step3. After "POWER OFF" is displayed on the LCD of the recorder, press the POWER button of the recorder.
- step4. The indicators of HDD 1 and HDD 2 momentary flash in green.  
When the power of the recorder is turned on, the connection is completed.

## 4. Setting

This unit can be used as a main device or copy device. Before using, set the details with the menu of the recorder.

### Setting of the recorder

#### ■ Setting of this unit for the main device or copy device

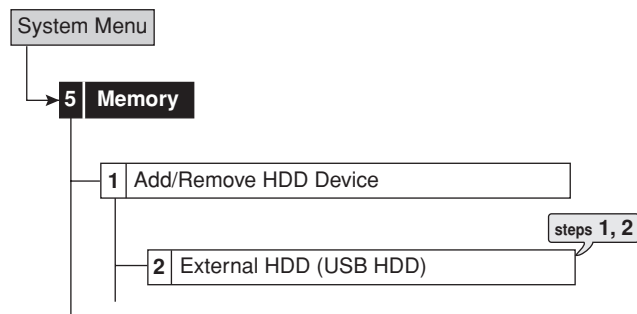

- step1. Make sure that the USB HDDs connected to the recorder are displayed in the screen of <External HDD (USB HDD)>.
  - When the "SB:" button of the desired ID number is pressed, the access LED on the device illuminates and you can check the corresponding HDD which is connected to the SERIAL BUS port.
- step2. Add the USB HDD for setting the main or copy device.
  - Main:** Registers for the main device. The numbers indicate the recording order.
  - Copy1:** Registers for the copy 1 device. The numbers indicate the recording order.
  - Copy2:** Registers for the copy 2 device. The numbers indicate the recording order.
  - Free:** Does not register as the main or copy device.
    - The button changes in the order of "Main," "Copy1," "Copy2," and "Free" each time you press the button.

- ⓘ
  - The copied data is transmitted in 2 MB units. The copy of up to 2 MB of the latest data may be delayed. Be careful when changing the copy device.
  - The maximum number of devices connected via the serial bus is 16, including the built-in DVD of the recorder and memory devices. This number is the total of devices registered as Main, Copy 1, and Copy 2.
  - The order of the main device used for recording is: internal HDD → USB HDD.

#### ◆ Notes for using this unit

This unit can be used as an additional memory or a copy device. However, when you carry out recording or playback in a high quality mode or at a high rate, pictures may be lost during recording or playback. Carry out trial operation before the actual operation.

#### ◆ Connecting this unit and setting the ID number

For connecting this unit to the recorder, use the USB 2.0 cable. The ID number is not necessary to be set because the unit automatically recognizes the HDD attached.

Make sure that the MAIN switch on the rear panel is turned off before connecting this unit.

#### ◆ The order of recording/playback when the recorder's HDDs and this unit are registered as the main device

The order of the recorder's internal HDD used for recording/playback is: internal A → internal B → internal C.

When all the built-in HDDs of the recorder are used up, recording/playback starts with the HDDs registered as Main in ascending sequence of their ID numbers.

Serial bus ID01 → Serial bus ID02 → •••• → Serial bus ID16 (at the maximum)

In case of serial bus HDD, the HDD which is added latest is registered last. However, the serial bus HDD newly connected can be registered to the middle number. When the HDD being used is removed, the HDD added is registered to the ID of the removed number.

#### ■ When copying data with this unit

##### ◆ Copy 1

Data can be copied by specifying the start and end points of copying. The points are specified by the date and time or the book mark. This function is useful for copying the data of the short period of time.

- ⓘ
  - Before executing the copy, make sure that the recorder and this unit are connected and the <Add/Remove HDD Device> (System Menu→Memory) is set in the recorder correctly.

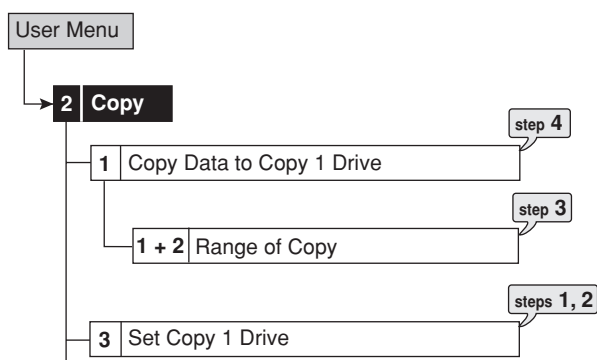

- step 1.** Set the camera number to be copied.
- The button function changes between “All Off” and “All On” each time you select this button. You can switch on and off for all the cameras easily by using this button.
  - The picture is not copied when there is no recorded picture of the set camera number or time.

- step 2.** Select “Other settings” and then set the detailed settings.

**From Main:** Sets the area which contains the data to be copied. The available setting items are “Normal,” “Alarm,” and “LPA.”

**To Copy 1:** Sets the group name to where the data is copied. The available setting items are “SerialBus,” “NAS,” “SCSI,” “DVD/CD,” and “USBMemory.” Set this unit to “SerialBus.”

**Copy Data:** Sets the data area to be copied. The available setting items are “Alarm” and “All.”

**Overwrite:** Selects whether or not to overwrite the existed data.

**Auto Eject:** Selects whether to eject media automatically when the copy is over. This menu is not available for this unit.



- “Alarm” appears for “From Main” when “Alarm Recording Area” (System Menu → Memory → Data Management Setting for Main Memory → Change Partition Setting) is set to other than “0 %” in the recorder.
  - “LPA” appears for “From Main” when “Long Pre-Alarm Area” (System Menu → Memory → Data Management Setting for Main Memory → Change Partition Setting) is set to other than “0 %” in the recorder.
- step 3.** Set the start, start/end, or end points of copy by specifying the date and time or the book mark number.
- Start:** Sets only the start point of copy.
- Start/End:** Sets the start and end points of copy.
- End:** Sets only the end point of copy.
- To set the book mark point, select “Bookmark” and then select the desired book mark number.
  - To copy from the oldest recording time, select “Copy Start Time.” To copy to the latest recording time, select “Copy End Time.”
- step 4.** Select “Execute.”
- The copy starts.
  - To stop the copy manually, select “Cancel” in the progress screen. The data which has been copied before cancelling is copied.

## ◆ Copy 2

This item is used to copy the data by specifying only the start point. The point is specified by the date and time or the bookmark. The copy continues until the end point of the recording data reaches or the media to be copied becomes full unless the copy is stopped manually (when “FIFO Overwrite” is set to “Off”). This function is useful for making backup of the recording data.



- Before executing the copy, make sure that the recorder and this unit are connected and the <Add/Remove HDD Device> (System Menu → Memory) is set in the recorder correctly.

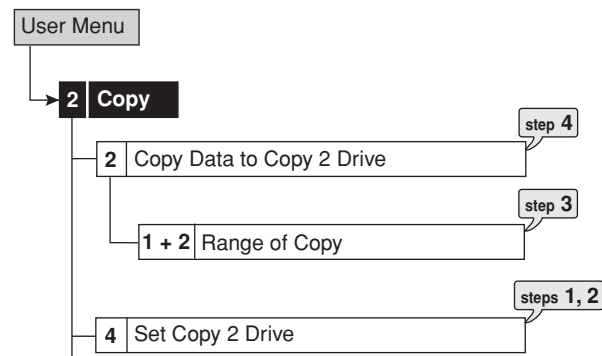

- step 1.** Set the camera number to be copied.
- The button function changes between “All Off” and “All On” each time you select this button. You can switch on and off for all the cameras easily by using this button.
  - The picture is not copied when there is no recorded picture of the set camera number or time.

- step 2.** Select “Other settings” and then set the detailed settings.

**From Main:** Sets the area which contains the data to be copied. The available setting items are “Normal,” “Alarm,” and “LPA.”

**To Copy 2:** Sets the group name to where the data is copied. The available setting items are “SerialBus,” “NAS,” “SCSI,” and “DVD/CD.” Set this unit to “SerialBus.”

**Copy Data:** Sets the data area to be copied. The available setting items are “Alarm” and “All.”

**Overwrite:** Selects whether or not to overwrite the existed data.

**Auto Eject:** Selects whether to eject media automatically when the copy is over. This menu is not available for this unit.

**FIFO Overwrite:** Selects whether to repeat copying from the start point of the media by overwriting the existed data, or to stop copying when the capacity of the media becomes full during copying.



- “Alarm” appears for “From Main” when “Alarm Recording Area” (System Menu → Memory → Data Management Setting for Main Memory → Change Partition Setting) is set to other than “0 %” in the recorder.

- “LPA” appears for “From Main” when “Long Pre-Alarm Area” (System Menu→Memory→Data Management Setting for Main Memory→Change Partition Setting) is set to other than “0 %” in the recorder.

- step3.** Set the start time of copy.  
**Start:** Sets the start point of copy.  
**Continue:** Starts copying from the end point of the previous copy.
- To set the start point using the book mark, select “Bookmark” and then select the desired book mark number.
  - To copy from the oldest recording time, select “Copy Start Time.”

- step4.** Select “Execute.”
- The copy starts.
  - To stop the copy manually, select “Cancel” in the screen of <Copy Data to Copy 2 Drive>. The data which has been copied before cancelling is copied.

- ⚠
- The warning is displayed when the copied range exceeds the available capacity of the device to be copied when “FIFO Overwrite” is set to “Off” and copy destination is HDD. In this case, set the copy setting again with narrower copy range or use a copy device with larger capacity.
  - When the copy is performed during recording, the picture of the recording start and end points may not be recorded.

- ↔
- The progress bar of copy is not displayed for copy 2.
  - The picture data is processed in 2 MB unit. Therefore the data is copied in 2 MB unit from the start point of the designated range when copying.

## 5. Attaching and removing the HDD

Up to 2 HDDs can be mounted on this unit. The attaching, removing and replacing method of the HDDs are as follows.

- ⚠
- Disconnect the power supply from the Mains before installing or removing the HDD.
  - When attaching the HDDs, attach in the order of HDD 1, and 2.

### ■ Precautions for installation

#### ◆ Precautions for attaching or removing the HDD

- ⚠
- Do not attach or remove the HDD unnecessarily. Attaching or removing the HDD of DX-ZD5UE(Z) is intended to replace the faulty HDD or add the HDD when starting operation for the first time because of the structure of the connectors. It is not presumed to be used as a removable HDD.

- Make sure that the MAIN switch on the rear panel is turned OFF when attaching or removing the HDD. Wait at least 1 minute after turning off the power. When a recorder is connected, turn off the recorder, too.
- Do not remove the top cover of the unit.
- When a power failure occurs during recording, avoid adding, replacing or transporting the HDD. In this case, as the recorded data may be erased, turn the power back on to boot up the unit normally with the HDD that was being used at the time of the power failure attached. Then add, replace, or transport the HDD.
- HDD is very delicate. Handle the HDD with care and follow the precautions below because even a small shock may damage the internal components of the HDD.
  - Do not drop the HDD. Also do not put the metallic object such as a coin or a screw driver into the HDD tray.
  - Do not place the HDD on a desk or a table directly. Put a thick cushion under the HDD because even a small shock may damage the internal components of the HDD.
  - Do not use an electric screwdriver. Vibrations and shocks caused by an electric screwdriver may damage the internal components of the HDD.
  - When replacing the HDD, do not knock the HDD with other components such as the another HDD and the HDD tray.
  - Do not knock the HDD with tools such as a driver when replacing the HDD.
- The following HDD has been tested and compatibility is ensured. This information is as of December 2004. Supply of this HDD may be stopped or it may be changed without notice by its manufacturer. Consult your dealer for the latest information or use of other HDDs. When you attach multiple HDDs, normally use the HDDs of the same capacity and the same model name.

<Hitachi Global Storage Technologies>  
 HDS724040KLSA80 (400 GB, S-ATA)

### ■ When attaching a HDD

- step1.** Push the left end of each screw covers on both sides of the cover to open.

- ⚠
- Do not leave the screw cover open for general use.

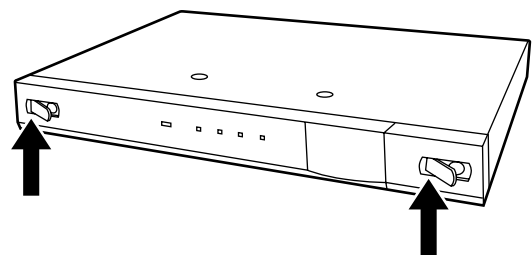

step2. Remove the screws.

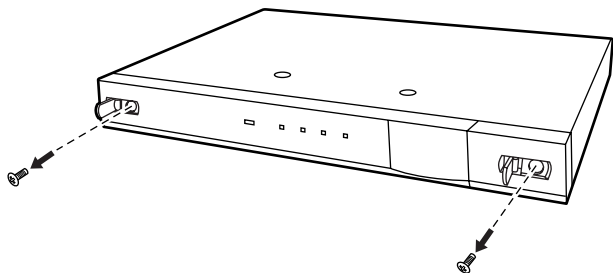

step3. Remove the front covers.  
 • Remove the cover on the right side first.  
 • Then, push the left side cover to the right to remove.

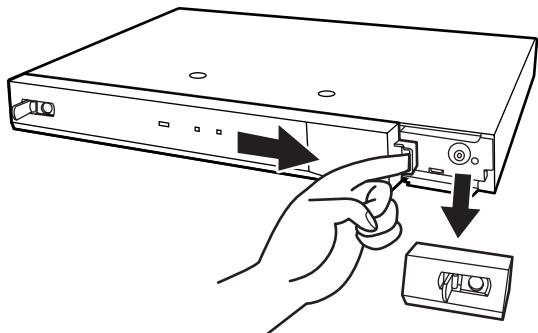

step4. Disconnect the cord connected to the circuit board on the metal part.

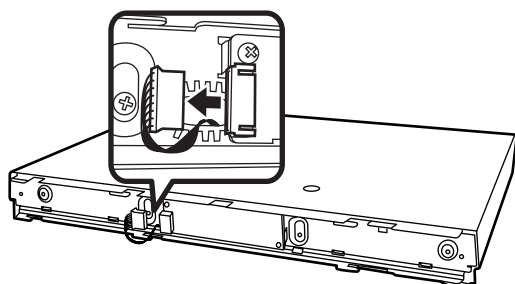

step5. Remove the metal part.  
 • Remove 4 screws on the metal part.

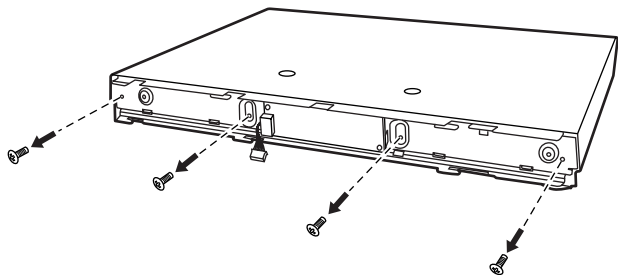

step6. Pull out the HDD tray completely.

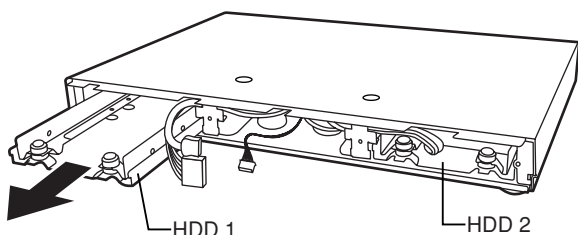

step7. Attach the new HDD onto the HDD tray with four screws.  
 • Make sure to attach the HDD in the correct direction.



• When attaching the HDD to this unit, use the supplied screws.

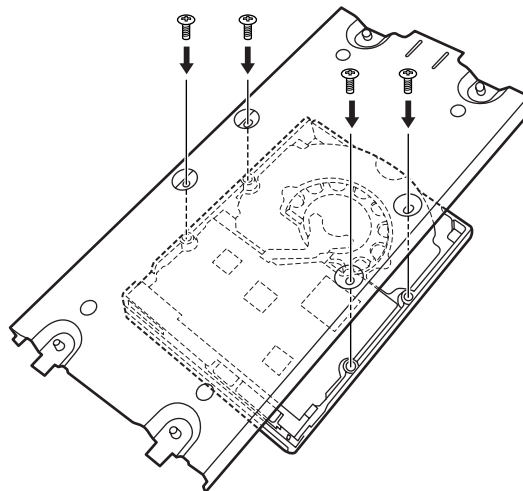

step8. Insert the hard disk tray halfway.

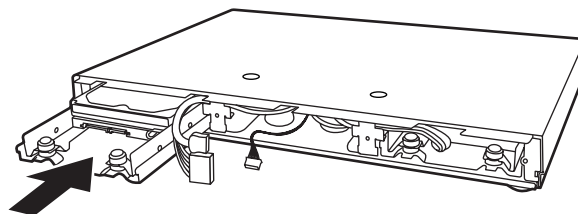

step9. Connect the cords.

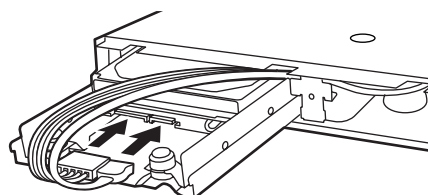

step10. Insert the hard disk tray completely.

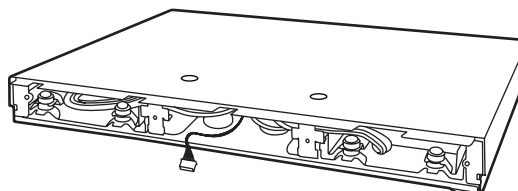

# Connections

**step11.** Attach the metal part.

- Adjust the upper side first, then push the lower side into the unit.
- Take care not to deform the springs.

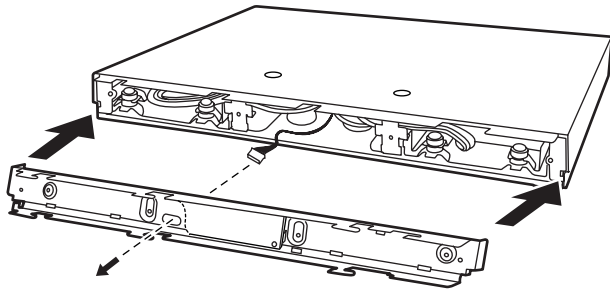

**step12.** Fix the metal part with four screws.

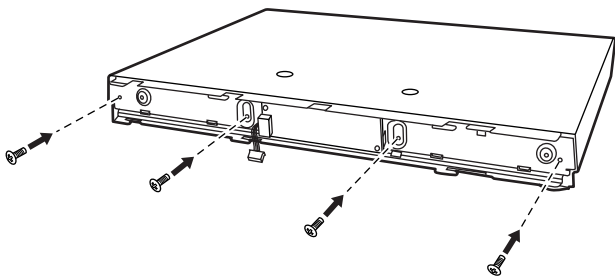

**step13.** Connect the cord to the circuit board on the metal part.

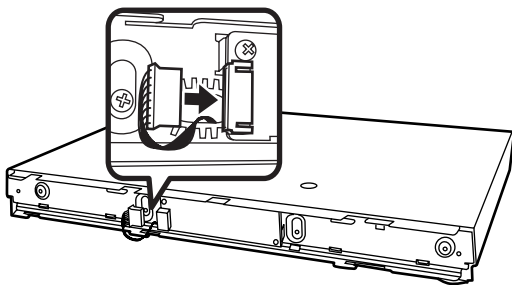

**step14.** Attach the front covers.

- Attach the left side cover and push to the left.
- Then, attach the right side cover.

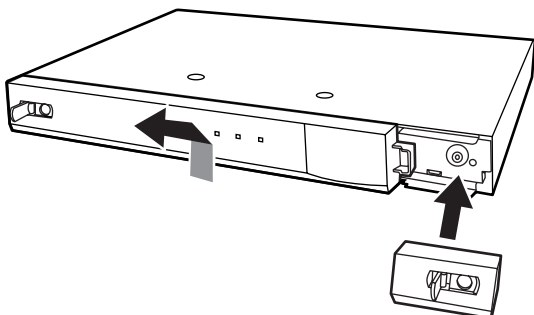

**step15.** Fix the front covers with two screws.

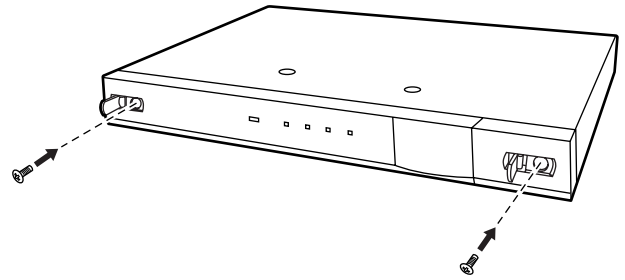

**step16.** Close the left end of each screw covers on both sides of the cover.

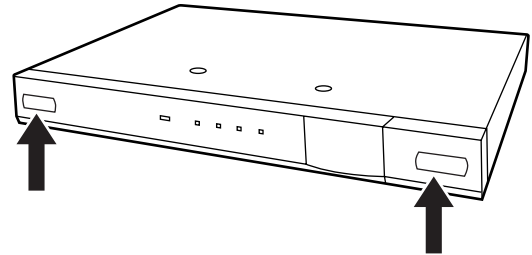

- Follow the same procedures when attaching a HDD to HDD 2, or removing or replacing the HDDs.

## 6. Troubleshooting

If problems with the unit persist even after you've followed the suggestions below, please disconnect the power cord and contact the retailer from whom you purchased the unit.

Description of problem	Please consult the following
The unit is not turned on.	<ul style="list-style-type: none"> <li>• Is the power cord properly plugged in?</li> <li>• Is the EXTERNAL CONTROL switch set to ON though the DC 12 V OUT terminal of the recorder and the CONT IN terminal of this unit are not connected ?</li> </ul>
This unit does not work correctly.	<ul style="list-style-type: none"> <li>• Is the USB cable connected correctly?</li> <li>• Are the menus set correctly in the recorder?</li> <li>• Are the recording devices connected exceeding the specified connectable number?</li> </ul>
TEMP indicator illuminates.	<ul style="list-style-type: none"> <li>• Turn off the power. Turn on the power again after the internal temperature drops.</li> </ul>
FAN indicator illuminates.	<ul style="list-style-type: none"> <li>• Replace the fan with new one. Ask your dealer to replace the fan.</li> </ul>

## 7. Maintenance

The elapsed operating time, which can be a guide to know the periodic maintenance timing, is available in the <Elapsed Operating Time> menu (System Menu → Service Info → Elapsed Operating Time) of the recorder. Refer to the installer's manual of the recorder. The indication of the operating time of the recorder may vary from the actual operating time. It is recommended to use this indication just for your reference.

When this unit is registered as a Copy 1 device, check the indication of Copy 1, SerialBus.

When this unit is registered as a Copy 2 device, check the indication of Copy 2, SerialBus.

When this unit is registered as a Main device, the elapsed operating time of this unit is not displayed. (The elapsed operating time of the recorder connected with this unit is displayed.)

# Recording time table

## ■ Continuous recording time table

### ◆ HDD continuous recording time

Displays the estimated recordable time (when recording on two 250 GB HDDs).



- The following table shows the total number of recordable frames of all the cameras which are set for recording.

- When recording data in NTSC system
- Without audio recording

d : day, h : hour

Number of frames /sec. Picture grade	240	120	80	60	48	32	30	16	13
Super	15h	1d7h	1d23h	2d15h	3d7h	4d22h	5d6h	9d21h	12d4h
Fine	18h	1d12h	2d7h	3d1h	3d20h	5d18h	6d3h	11d13h	14d5h
High	22h	1d20h	2d18h	3d16h	4d15h	6d22h	7d9h	13d21h	17d2h
Standard	1d3h	2d7h	3d11h	4d15h	5d19h	8d16h	9d6h	17d9h	21d9h
Basic	1d13h	3d2h	4d15h	6d4h	7d17h	11d14h	12d9h	23d4h	28d13h
Long	2d7h	4d15h	6d23h	9d7h	11d14h	17d10h	18d14h	34d20h	42d21h

Number of frames /sec. Picture grade	10	8	4	2	1	0.5	0.25	0.125	Number of recording field
Super	15d19h	19d18h	39d13h	79d3h	158d7h	316d15h	633d7h	1266d15h	13,678,000
Fine	18d11h	23d2h	46d5h	92d11h	184d22h	369d21h	739d19h	1479d14h	15,978,000
High	22d5h	27d18h	55d13h	111d2h	222d5h	444d10h	888d20h	1777d16h	19,198,000
Standard	27d19h	34d18h	69d12h	139d1h	278d2h	556d5h	1112d10h	2224d20h	24,026,000
Basic	37d3h	46d9h	92d19h	185d15h	371d6h	742d12h	1485d1h	2970d3h	32,077,000
Long	55d18h	69d16h	139d9h	278d19h	557d14h	1115d4h	2230d8h	4460d17h	48,174,000

• With audio recording <Audio recording using 12.8 KHz PCM sampling is possible.>

d : day, h : hour

Number of frames /sec.		240	120	80	60	48	32	30	16	13
Super	Audio Channel 1	15h	1d7h	1d23h	2d14h	3d6h	4d21h	5d5h	9d16h	11d20h
	Audio Channel 2	15h	1d7h	1d23h	2d14h	3d6h	4d20h	5d3h	9d11h	11d13h
	Audio Channel 3	15h	1d7h	1d22h	2d14h	3d5h	4d18h	5d2h	9d6h	11d6h
	Audio Channel 4	15h	1d7h	1d22h	2d13h	3d4h	4d17h	5d	9d2h	10d23h
Fine	Audio Channel 1	18h	1d12h	2d7h	3d1h	3d19h	5d16h	6d1h	11d6h	13d18h
	Audio Channel 2	18h	1d12h	2d6h	3d	3d18h	5d15h	5d23h	10d23h	13d8h
	Audio Channel 3	18h	1d12h	2d6h	3d	3d18h	5d13h	5d22h	10d17h	12d23h
	Audio Channel 4	18h	1d12h	2d6h	2d23h	3d17h	5d11h	5d20h	10d11h	12d14h
High	Audio Channel 1	22h	1d20h	2d18h	3d16h	4d13h	6d20h	7d6h	13d11h	16d11h
	Audio Channel 2	22h	1d20h	2d17h	3d15h	4d12h	6d17h	7d4h	13d1h	15d20h
	Audio Channel 3	22h	1d19h	2d17h	3d14h	4d11h	6d15h	7d1h	12d16h	15d7h
	Audio Channel 4	22h	1d19h	2d17h	3d14h	4d10h	6d12h	6d22h	12d8h	14d19h
Standard	Audio Channel 1	1d3h	2d7h	3d10h	4d14h	5d17h	8d12h	9d1h	16d17h	20d9h
	Audio Channel 2	1d3h	2d7h	3d10h	4d12h	5d15h	8d8h	8d21h	16d2h	19d12h
	Audio Channel 3	1d3h	2d6h	3d9h	4d11h	5d13h	8d5h	8d17h	15d13h	18d16h
	Audio Channel 4	1d3h	2d6h	3d8h	4d10h	5d12h	8d1h	8d13h	15d	17d22h
Basic	Audio Channel 1	1d12h	3d1h	4d14h	6d2h	7d14h	11d7h	12d	22d1h	26d20h
	Audio Channel 2	1d12h	3d1h	4d13h	6d	7d11h	11d	11d17h	21d	25d7h
	Audio Channel 3	1d12h	3d	4d12h	5d22h	7d8h	10d18h	11d10h	20d1h	23d22h
	Audio Channel 4	1d12h	3d	4d10h	5d20h	7d5h	10d12h	11d3h	19d4h	22d17h
Long	Audio Channel 1	2d7h	4d14h	6d20h	9d2h	11d7h	16d18h	17d20h	32d7h	39d3h
	Audio Channel 2	2d7h	4d13h	6d18h	8d22h	11d	16d3h	17d3h	30d3h	35d23h
	Audio Channel 3	2d6h	4d12h	6d15h	8d17h	10d18h	15d14h	16d12h	28d5h	33d6h
	Audio Channel 4	2d6h	4d11h	6d13h	8d13h	10d12h	15d1h	15d22h	26d13h	30d23h

Number of frames /sec.		10	8	4	2	1	0.5	0.25	0.125
Super	Audio Channel 1	15d6h	18d22h	36d8h	67d4h	116d15h	184d17h	260d18h	328d9h
	Audio Channel 2	14d18h	18d4h	33d14h	58d7h	92d8h	130d9h	164d4h	188d15h
	Audio Channel 3	14d7h	17d10h	31d5h	51d13h	76d10h	100d18h	119d19h	132d8h
	Audio Channel 4	13d20h	16d19h	29d3h	46d4h	65d4h	82d2h	94d7h	101d21h
Fine	Audio Channel 1	17d18h	21d23h	41d21h	76d12h	130d13h	201d18h	277d10h	341d10h
	Audio Channel 2	17d1h	20d22h	38d6h	65d6h	100d21h	138d17h	170d17h	192d23h
	Audio Channel 3	16d10h	19d23h	35d5h	56d21h	82d4h	105d16h	123d7h	134d12h
	Audio Channel 4	15d20h	19d3h	32d15h	50d10h	69d8h	85d8h	96d11h	103d5h
High	Audio Channel 1	21d3h	26d3h	49d9h	88d21h	148d3h	222d5h	296d6h	355d12h
	Audio Channel 2	20d4h	24d16h	44d10h	74d1h	111d2h	148d3h	177d18h	197d12h
	Audio Channel 3	19d7h	23d9h	40d9h	63d11h	88d21h	111d2h	126d23h	136d17h
	Audio Channel 4	18d12h	22d5h	37d	55d13h	74d1h	88d21h	98d18h	104d13h
Standard	Audio Channel 1	26d4h	32d5h	60d3h	105d22h	171d3h	247d4h	317d20h	370d19h
	Audio Channel 2	24d17h	30d1h	52d23h	85d13h	123d14h	158d22h	185d9h	202d6h
	Audio Channel 3	23d10h	28d3h	47d8h	71d18h	96d17h	117d2h	130d20h	139d1h
	Audio Channel 4	22d5h	26d11h	42d18h	61d19h	79d11h	92d16h	101d3h	105d22h
Basic	Audio Channel 1	34d6h	42d	76d19h	131d	202d12h	278d10h	342d17h	387d9h
	Audio Channel 2	31d19h	38d9h	65d12h	101d6h	139d5h	171d8h	193d16h	207d5h
	Audio Channel 3	29d16h	35d8h	57d2h	82d12h	106d1h	123d18h	135d	141d10h
	Audio Channel 4	27d20h	32d18h	50d15h	69d14h	85d16h	96d20h	103d14h	107d8h
Long	Audio Channel 1	49d13h	60d6h	106d4h	171d13h	247d19h	318d14h	371d17h	405d12h
	Audio Channel 2	44d14h	53d2h	85d18h	123d21h	159d7h	185d20h	202d18h	212d9h
	Audio Channel 3	40d13h	47d10h	71d22h	96d23h	117d9h	131d4h	139d9h	143d21h
	Audio Channel 4	37d4h	42d21h	61d22h	79d15h	92d22h	101d9h	106d4h	108d19h

- ⓘ
- Continuous recordable time and the estimated time displayed on the menu screen are the continuous recordable time when operating this unit and is not the product warranty period. Furthermore, it is not the period that guarantees the operation of used parts.

## Recording time table

- When recording data in PAL system
- Without audio recording

d : day, h : hour

Number of frames /sec. Picture grade	200	100	66.7	50	40	33.3	25	16	13
Super	16h	1d9h	2d1h	2d18h	3d11h	4d1h	5d12h	8d15h	10d15h
Fine	19h	1d15h	2d10h	3d6h	4d1h	4d19h	6d12h	10d4h	12d12h
High	23h	1d23h	2d23h	3d23h	4d22h	5d19h	7d22h	12d9h	15d6h
Standard	1d6h	2d12h	3d18h	5d1h	6d7h	7d10h	10d2h	15d19h	19d10h
Basic	1d17h	3d11h	5d5h	6d23h	8d16h	10d5h	13d22h	21d17h	26d18h
Long	2d18h	5d13h	8d8h	11d3h	13d22h	16d9h	22d7h	34d20h	42d21h

Number of frames /sec. Picture grade	10	8	4	2	1	0.5	0.25	0.125	Number of recording field
Super	13d20h	17d7h	34d14h	69d4h	138d8h	276d17h	553d11h	1106d22h	11,953,000
Fine	16d7h	20d9h	40d18h	81d12h	163d	326d1h	652d2h	1304d5h	14,084,000
High	19d19h	24d18h	49d13h	99d3h	198d6h	396d12h	793d	1586d1h	17,128,000
Standard	25d6h	31d14h	63d4h	126d8h	252d16h	505d9h	1010d19h	2021d14h	21,832,000
Basic	34d19h	43d11h	86d23h	173d23h	347d23h	695d23h	1391d22h	2783d20h	30,064,000
Long	55d18h	69d16h	139d9h	278d19h	557d14h	1115d4h	2230d8h	4460d17h	48,174,000

• With audio recording <Audio recording using 12.8 KHz PCM sampling is possible.>

d : day, h : hour

Number of frames /sec.		200	100	66.7	50	40	33.3	25	16	13
Picture grade										
Super	Audio Channel 1	16h	1d9h	2d1h	2d18h	3d10h	4d	5d11h	8d11h	10d9h
	Audio Channel 2	16h	1d9h	2d1h	2d17h	3d9h	3d23h	5d9h	8d7h	10d3h
	Audio Channel 3	16h	1d8h	2d1h	2d17h	3d9h	3d23h	5d8h	8d4h	9d22h
	Audio Channel 4	16h	1d8h	2d	2d16h	3d8h	3d22h	5d6h	8d	9d17h
Fine	Audio Channel 1	19h	1d14h	2d10h	3d5h	4d	4d17h	6d10h	9d23h	12d4h
	Audio Channel 2	19h	1d14h	2d9h	3d5h	4d	4d16h	6d8h	9d17h	11d20h
	Audio Channel 3	19h	1d14h	2d9h	3d4h	3d23h	4d15h	6d5h	9d12h	11d13h
	Audio Channel 4	19h	1d14h	2d9h	3d4h	3d22h	4d14h	6d3h	9d7h	11d6h
High	Audio Channel 1	23h	1d23h	2d22h	3d22h	4d21h	5d18h	7d18h	12d1h	14d17h
	Audio Channel 2	23h	1d23h	2d22h	3d21h	4d20h	5d16h	7d15h	11d17h	14d6h
	Audio Channel 3	23h	1d22h	2d21h	3d20h	4d19h	5d14h	7d12h	11d10h	13d19h
	Audio Channel 4	23h	1d22h	2d21h	3d19h	4d17h	5d12h	7d9h	11d3h	13d9h
Standard	Audio Channel 1	1d6h	2d12h	3d18h	4d23h	6d5h	7d7h	9d21h	15d6h	18d14h
	Audio Channel 2	1d6h	2d11h	3d17h	4d22h	6d3h	7d4h	9d16h	14d17h	17d21h
	Audio Channel 3	1d6h	2d11h	3d16h	4d21h	6d1h	7d1h	9d11h	14d6h	17d4h
	Audio Channel 4	1d5h	2d11h	3d15h	4d20h	5d23h	6d23h	9d6h	13d19h	16d13h
Basic	Audio Channel 1	1d17h	3d10h	5d3h	6d20h	8d12h	10d	13d11h	20d17h	25d6h
	Audio Channel 2	1d17h	3d10h	5d2h	6d17h	8d8h	9d18h	13d2h	19d19h	23d21h
	Audio Channel 3	1d17h	3d9h	5d	6d15h	8d5h	9d13h	12d17h	18d23h	22d16h
	Audio Channel 4	1d17h	3d8h	4d23h	6d13h	8d1h	9d8h	12d8h	18d4h	21d13h
Long	Audio Channel 1	2d18h	5d12h	8d4h	10d21h	13d12h	15d19h	21d5h	32d7h	39d3h
	Audio Channel 2	2d18h	5d10h	8d1h	10d14h	13d2h	15d6h	20d6h	30d3h	35d23h
	Audio Channel 3	2d17h	5d8h	7d21h	10d8h	12d17h	14d18h	19d9h	28d5h	33d6h
	Audio Channel 4	2d17h	5d7h	7d18h	10d3h	12d9h	14d7h	18d14h	26d13h	30d23h

Number of frames /sec.		10	8	4	2	1	0.5	0.25	0.125
Picture grade									
Super	Audio Channel 1	13d10h	16d15h	32d2h	59d20h	105d10h	170d7h	245d23h	316d6h
	Audio Channel 2	13d	16d1h	29d22h	52d17h	85d3h	122d23h	158d3h	184d11h
	Audio Channel 3	12d15h	15d11h	28d	47d2h	71d9h	96d6h	116d12h	130d5h
	Audio Channel 4	12d7h	14d23h	26d8h	42d13h	61d11h	79d1h	92d5h	100d15h
Fine	Audio Channel 1	15d17h	19d11h	37d7h	68d20h	119d4h	187d21h	263d22h	330d22h
	Audio Channel 2	15d4h	18d15h	34d10h	59d14h	93d22h	131d23h	165d11h	189d12h
	Audio Channel 3	14d16h	17d21h	31d22h	52d12h	77d12h	101d16h	120d11h	132d18h
	Audio Channel 4	14d5h	17d5h	29d19h	46d23h	65d23h	82d17h	94d18h	102d4h
High	Audio Channel 1	18d23h	23d11h	44d14h	81d	137d1h	209d11h	284d16h	346d22h
	Audio Channel 2	18d4h	22d7h	40d12h	68d12h	104d17h	142d8h	173d11h	194d18h
	Audio Channel 3	17d11h	21d5h	37d3h	59d8h	84d18h	107d18h	124d17h	135d9h
	Audio Channel 4	16d19h	20d6h	34d6h	52d8h	71d4h	86d17h	97d9h	103d18h
Standard	Audio Channel 1	23d21h	29d11h	55d7h	98d9h	161d3h	236d13h	308d20h	364d13h
	Audio Channel 2	22d16h	27d15h	49d4h	80d13h	118d6h	154d10h	182d6h	200d8h
	Audio Channel 3	21d14h	26d	44d7h	68d5h	93d10h	114d15h	129d6h	138d2h
	Audio Channel 4	20d14h	24d14h	40d6h	59d3h	77d5h	91d3h	100d4h	105d9h
Basic	Audio Channel 1	32d6h	39d15h	72d18h	125d2h	195d8h	271d14h	337d10h	383d23h
	Audio Channel 2	30d2h	36d9h	62d13h	97d16h	135d19h	168d17h	191d23h	206d5h
	Audio Channel 3	28d4h	33d15h	54d20h	80d2h	104d1h	122d8h	134d3h	140d22h
	Audio Channel 4	26d12h	31d6h	48d20h	67d21h	84d8h	95d23h	103d2h	107d1h
Long	Audio Channel 1	49d13h	60d6h	106d4h	171d13h	247d19h	318d14h	371d17h	405d12h
	Audio Channel 2	44d14h	53d2h	85d18h	123d21h	159d7h	185d20h	202d18h	212d9h
	Audio Channel 3	40d13h	47d10h	71d22h	96d23h	117d9h	131d4h	139d9h	143d21h
	Audio Channel 4	37d4h	42d21h	61d22h	79d15h	92d22h	101d9h	106d4h	108d19h

- ⓘ
- Continuous recordable time and the estimated time displayed on the menu screen are the continuous recordable time when operating this unit and is not the product warranty period. Furthermore, it is not the period that guarantees the operation of used parts.

# Specifications

## General

Rated Power Supply:	100 to 240 V AC $\pm$ 10 %, 50/60 Hz
Rated Input:	0.7 - 0.4 A (100-240 V)
Operating Temperature:	41 °F-104 °F (5 °C to 40 °C)
Relative Humidity:	Max. 80 (%)
Altitude:	Max. 2000 (m)
Dimensions:	424 (Width) x 361 (Depth) x 49 (Height) (mm)
Weight:	5 kg

## Control terminals

CONT IN	Input terminal working with the power supply of the recorder
CONT OUT	Output terminal working with the power supply of the recorder
GND (Ground)	For grounding
TEMP ALM	Output terminal for detecting abnormality of temperature (open collector output) Active: "Low" Level Max. Drive current 7 mA DC. Non active: Open. Max. Voltage 24 V DC.
FAN ALM	Output terminal for detecting abnormality of the fan (open collector output) Active: "Low" Level Max. Drive current 7 mA DC. Non active: Open. Max. Voltage 24 V DC.

## EXTERNAL CONTROL:

When set to ON:	Power is supplied to the HDD when 12V of voltage is applied to the input terminal working with the power supply
When set to OFF:	Power is always supplied to the HDD.

## Serial bus terminal

Serial bus terminal (2 terminals) (Only DX-ZD5UE(Z) is connectable.)

Accessories:	USB2.0 cable	1
	Screws	8
	User's manual (this manual)	1
	Power cord	3

## Control input/output terminals and circuits

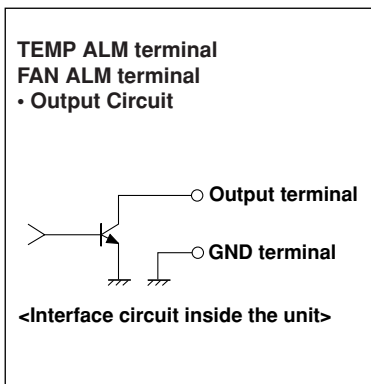

Design and specifications are subject to change without notice.

## **MITSUBISHI DIGITAL ELECTRONICS AMERICA, INC.**

9351 Jeronimo Road, Irvine, CA 92618, U.S.A.

Phone 949-465-6000

www.mitsubishi-imaging.com

Tech Support 888-307-0309

tsupport@mdea.me.com

### **UK**

Mitsubishi Electric Europe B.V.

UK Branch Office

Visual Information Systems Division

Travellers Lane Hatfield Herts AL10 8XB

Telephone: +44 (1707)-278 684

Fax: +44 (1707)-278 541

### **GERMANY**

Mitsubishi Electric Europe B.V.

German Branch Office

Electric Visual Systems

Gothaer Str. 8 40880 Ratingen Germany

Telephone: +49 (2102)-486 9250

Fax: +49 (2102)-486 7320

### **SPAIN**

Mitsubishi Electric Europe B.V.

Spanish Branch Office

Ctra. de Rubi, 76-80 Apdo.420

08190 Sant Cugat del Valles

(Barcelona) SPAIN

Telephone: +34 (93)-565 3154

Fax: +34 (93)-589 4388

### **FRANCE**

Mitsubishi Electric Europe B.V.

French Branch Office 25,

Boulevard des Bouvets 92741 Nanterre

Cedex

Telephone: +33 (1)-5568 5500

Fax: +33 (1)-5568 5731

### **ITALY**

Mitsubishi Electric Europe B.V.

Italian Branch Office

Centro Direzionale Colleoni

Palazzo Perseo - Ingresso 2, Via

Paracelso 12, 20041 Agrate Brianza, Italy

Telephone: +39 (039)-605 31

Fax: + 39 (039)-605 3214

### **The Netherlands**

Mitsubishi Electric Benelux

A Division of Mitsubishi Electric Europe B.V.

Niiverheidsweg 23A, 3641 RP Mijdrecht

Netherlands.

Telephone: +31 (297)-282 461

Fax: +31 (297)-283 936

### **Sweden**

Mitsubishi Electric Scandinavia

Hammarbacken 14 Box750 SE-191 27

Sollentuna Sweden

Telephone: +46 (8)-625 1000

Fax: +46 (8)-35 1132

### **Ireland**

Mitsubishi Electric Ireland

A Division of Mitsubishi Electric Europe B.V.

Westgate Business Park, Ballymount,

Dublin 24. Ireland

Telephone: +353 (1)-419 8800

Fax: +353 (1)-419 8895