



DIGITAL COLOUR PRINTER

MODEL

CP3020DE

OPERATION MANUAL

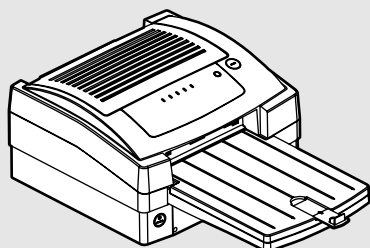

THIS OPERATION MANUAL IS IMPORTANT
TO YOU.
PLEASE READ IT BEFORE USING YOUR
DIGITAL COLOUR PRINTER.

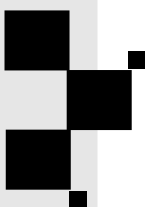

DIGITAL COLOUR PRINTER

This digital colour printer complies with the requirements of the EC Directive 89/336/EEC, 73/23/EEC and 93/68/EEC.

The electro-magnetic susceptibility has been chosen at a level that gains proper operation in residential areas, on business and light industrial premises and on small-scale enterprises, inside as well as outside of the buildings. All places of operation are characterised by their connection to the public low voltage power supply system.

CONTENTS

Contents	1
Safety precautions	2-4
Special features	5
Unpacking	6
Features and functions	7-8
Front panel	7
Rear panel	8
Cancelling continuous printing	8
Connections	9
Connection with USB interface	9
Before operation	10-16
Paper sheet set	10
Removing the shipping inserts	10
Installation of ink sheet	11
Installation of print paper	12-13
Usage and storage of paper sheet set	14
Installing printer driver	15
Troubleshooting	16-19
Indication on the front panel & countermeasures	16
Before calling for service	17
Overcoming paper jams	18
Repairing a torn ink sheet	19
Cleaning	20
Spec & options	21

PRECAUTIONS

FEATURES

CONNECTIONS

PREPARATION

TROUBLE-SHOOTING

OTHERS

SAFETY PRECAUTIONS

In the interest of safety, please observe the following precautions:

POWER REQUIREMENT

This product is designed for operation on 220-240V AC 50/60Hz. Never connect to any outlet or power supply having a different voltage or frequency.

WARNING: THIS APPARATUS MUST BE GROUNDED.

AVERTISSEMENT: CET APPAREIL DOIT ETRE MIS A LA TERRE.

PROTECTIVE MEASURES

IF ABNORMALITIES ARISE,

If the printer emits smoke or abnormal sounds, immediately unplug the power cord from the printer or power outlet. Continued use may be dangerous. Contact your dealer about having the printer checked and serviced.

NEVER INSERT ANY OBJECT INTO THE UNIT

Nothing other than supplies for this printer should ever be inserted into the printer. Other items can cause a safety hazard and extensive damage to the mechanism and electronics.

DO NOT SET HEAVY OBJECTS ON TOP OF THE UNIT

Heavy objects can damage the unit and/or cause misoperation.

AVOID DAMAGING THE POWER CORD

Do not set anything heavy on the power cord nor allow it to become pinched, or cut. If the power cord becomes damaged, replace it immediately to avoid shock hazard or electrical fire.

When the power cord is replaced, use the same type as originally supplied; it is designed to reduce interference to radio & TV reception.

When unplugging the power cord, hold the plug, and remove it carefully.

KEEP THE UNIT DRY - DO NOT PLACE WATER OR OTHER LIQUID CONTAINERS, FLOWER VASES/POTS ON TOP OF THE UNIT

Liquids that get into the unit can cause serious damage to the unit and potential shock or fire danger. If liquid is spilled into or seeps into the unit, unplug the Power Cord immediately and seek service as soon as possible to avoid additional or possible damage due to corrosion.

"In the interest of safety, avoid handling of liquids near the unit."

DO NOT REMOVE THE CABINET. THERE ARE NO USER SERVICEABLE PARTS INSIDE AND YOU WILL EXPOSE YOURSELF TO HAZARDOUS VOLTAGES AND/OR YOU MAY CAUSE DAMAGE TO THE UNIT.

Touching internal parts is dangerous, and may cause a malfunction. Contact your dealer to carry out internal checks and adjustments. Disconnect the power cord before opening the cover to clear a paper jam, etc.

UNPLUG THE POWER CORD DURING A LONG ABSENCE OR DURING AN ELECTRICAL STORM

Turn off the Main Power switch and unplug the power cord during a long absence or during an electrical storm.

WHEN TRANSPORTING THE UNIT

When transporting the unit, remove the ink cassette and paper. And make sure to attach the shipping inserts on the slot or the rollers may be deformed.

DO NOT INSERT YOUR FINGERS OR ANY OBJECT INTO THE PAPER OUTLET DURING PRINTING

Inside the paper outlet is a roller for taking out the print paper. If you insert your fingers, you may get injured.

DO NOT TOUCH THE THERMAL HEAD

It becomes hot during printing and may remain hot for a time, causing injury. Oils, salts and moisture from your hands will contaminate the head and may spoil the prints.

CONNECTING CABLES

Use the power cord supplied with the printer.

PRECAUTIONS

FEATURES

CONNECTIONS

PREPARATION

TROUBLE-
SHOOTING

OTHERS

INSTALLATION LOCATIONS

MAINTAIN GOOD VENTILATION

Ventilation slots and holes are provided on the rear of this unit. Place the unit on a hard and level surface and locate at least 17 cm (6.7 inches) (top) and 5 cm (2 inches) (sides), from walls to insure proper ventilation. When installing the unit in a system rack, leave space between the unit and the back of the rack.

UNSUITABLE LOCATIONS

Avoid installing the printer in unstable locations with high vibration or in hot-springs areas where hydrogen sulfide and acidic ions are likely to be generated.

PLACES WITH HIGH HUMIDITY AND DUST

Do not place the unit in locations with high humidity and dust. They can cause extensive damage. Avoid places where unit is likely to be exposed to oily fumes and vapours.

PLACES LIKELY TO BE EXTREMELY HOT

Places exposed to direct sunlight, or near heating appliances can attain extremely high temperatures which may deform the cabinet, or cause other damage.

PLACE THE UNIT ON A HORIZONTAL SURFACE

The unit is likely to be affected if it is operated when tilted, inclined or in unstable places.

PROTECT AGAINST DEW FORMATION

When the unit is moved from a cold area into a warm area, moisture can condense inside the unit and prevent operation. Allow the temperature to stabilize before use.

OPERATING AMBIENT TEMPERATURE RANGE

The operating temperature range is 5°C to 35°C (41°F - 95°F) and humidity of 30 - 80%. When using the unit in a system rack, make sure that the temperature inside the rack does not exceed this range.

FOR LONG OPERATING LIFE

UNSUITABLE MATERIALS FOR THE PRINTER

Paint coat flaking and plastic deformation are likely to occur if the unit is wiped with chemical dusters, benzine, thinner or any other solvent, if rubber or PVC items are left in contact with the unit for a extended period, or if the unit is sprayed with insecticide.

CARE OF THE CABINET

Unplug and clean with a soft cloth slightly moistened with a mild soap and water solution. Allow to dry completely before operating. Never use petroleum based solutions or abrasive cleaners.

HEAD ABRASION

The thermal print head, like a video head, wears out. When it is worn, it becomes hard to print out fine details of the picture. Then it is necessary to replace the thermal head. Consult your dealer about having the head replaced.

CONNECTING DEVICES

Read thoroughly the Safety Notices, Cautions and "Operating Precautions" of the instruction booklets for the other devices connected with the unit.

CAUTION ON RELOCATING

When transporting the unit, make sure it is not likely to be subjected to impacts. This can be a primary cause for damage. Before moving the unit, make sure to disconnect the power cord from the power outlet, and the cables from the connected devices. Also make sure to remove the paper tray.

SAFETY PRECAUTIONS

OTHER CAUTIONS

Dust or other foreign matter adhering to the print paper or the ink cassette, or deformation resulting from exposure to extremely low or high temperatures could cause loss of colour, uneven colour or lines, or wrinkles in the print images.

NOTE:
MEMORIZED IMAGES ARE STORED IN VOLATILE MEMORY AND MAY BE LOST IN THE EVENT OF POWER FLUCTUATION OR MALFUNCTION.

PRECAUTIONS
FEATURES
CONNECTIONS
PREPARATION
TROUBLE-SHOOTING
OTHERS

SPECIAL FEATURES

SPECIAL FEATURES

2 PRINT SIZES ARE AVAILABLE DEPENDING ON INK SHEET

2 printing sizes are [available depending on the 3-color YMC ink sheet being used](#). There are 2 types of ink sheet, matte and gloss to achieve the print finish required.

PRINTER DRIVER

The printer driver supports Windows® 98, Windows® Me, Windows® 2000 and Windows® XP.

PRINTING

This printer employs cut paper. Printing speed is approx. 77 seconds (in A4 size print).

HIGH QUALITY PRINTING

High quality print is available in dye sublimation mode. [The printer can generate](#) 256 gradients in each YMC, [approximately 16,700,000](#) colours total.

314 PPI HIGH RESOLUTION

314 PPI (Pixels Per Inch) high resolution gives precise illustrations and sharp photo images.

PRECAUTIONS

FEATURES

CONNECTIONS

PREPARATION

TROUBLE-SHOOTING

OTHERS

UNPACKING

UNPACKING

Take the unit out of the box by the following procedures. Make sure to check the contents.

1 Open the top of the box and remove the cardboard.

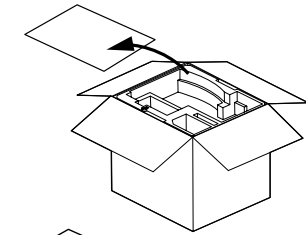

2 Remove the cushion with its contents. Be careful not to drop the contents.

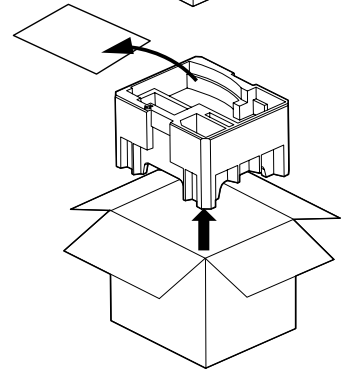

3 Take the unit out of the box carefully. Make sure to keep the unit horizontal.

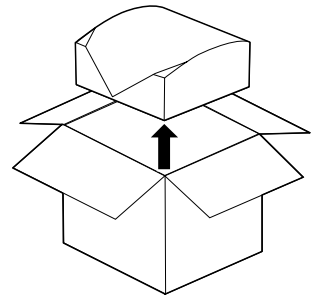

4 Unwrap the packing. Save the packaging in case you need to ship the printer.

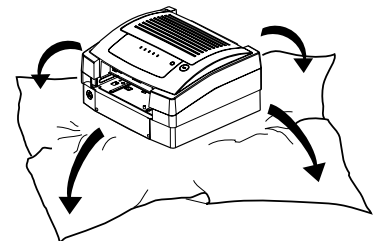

CONTENTS

Make sure to check the supplied contents on the cushion.

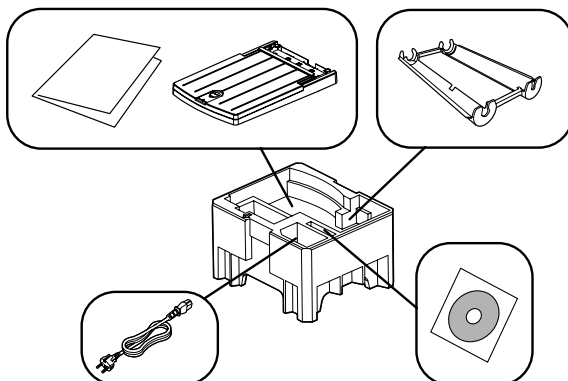

- Power cord (1)
- CD-ROM (1)
- Ink cassette (1)
- Paper tray (1)
- Quick setup guide (1)

PRECAUTIONS

FEATURES

CONNECTIONS

PREPARATION

TROUBLE-SHOOTING

OTHERS

FEATURES & FUNCTIONS

FRONT PANEL

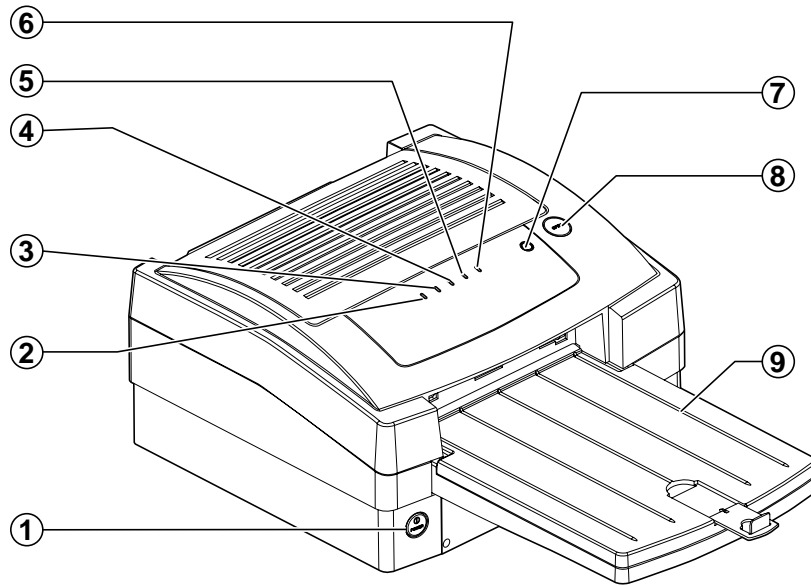

① POWER BUTTON

Press to turn on power. Press again to turn off power. When the power is turned on, POWER indicator illuminates.

② POWER INDICATOR

When the unit is turned on, this lamp lights up.

③ ALARM INDICATOR

When a paper jam occurs, this indicator blinks. When the top cover is open or an error concerning the combination of print paper and ink sheet occurs, it lights up.

④ MEDIA INDICATOR

When an error concerning print paper or ink sheet occurs or this unit is initializing, this indicator blinks. When an error concerning the combination of print paper and ink sheet occurs, it lights up.

⑤ DATA INDICATOR

When this unit is overheated or transferring data, this lamp blinks. It lights up during printing.

⑥ READY INDICATOR

When this unit is overheated, continuous printing is cancelled, or during initialisation, this indicator blinks. It lights up during data transfer, during printing, or when printing is available.

⑦ CANCEL BUTTON

Press to cancel continuous printing. See page 8 for continuous printing.

⑧ OPEN BUTTON

Press to open the top cover. Open the top cover when installing an ink sheet or clearing a paper jam.

NOTE

Do not press OPEN button during printing. Doing so may cause a print error and malfunction of the printer.

⑨ PAPER TRAY

Sets print paper. Remove shipping inserts before using. Printed paper comes out on this tray. Make sure to install it when using the printer. See page 12 for installing the tray.

PRECAUTIONS

FEATURES

CONNECTIONS

PREPARATION

TROUBLE-SHOOTING

OTHERS

REAR PANEL

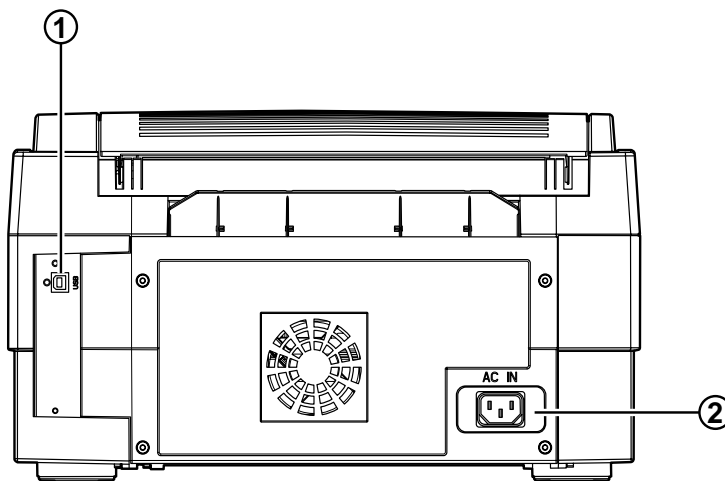

① USB PORT

Use this terminal to connect the unit to a device equipped with USB interface such as a personal computer. See page 9 for connection.

② AC LINE SOCKET

Connects to the provided power cord. Insert the cord firmly.

CANCELLING CONTINUOUS PRINTING

When printing two or more copies of one image, you can use continuous printing. The number of the copies can be set by the printer driver. Refer to the Read Me in the CD-ROM for setting the continuous [print option](#).

■ How to cancel continuous printing

- 1 Press **CANCEL** button during continuous printing on A4 size image.
- 2 **READY** indicator blinks. After completing the current [print](#), continuous printing is [cancelled](#).

NOTE

[Cancelling](#) continuous printing is applicable only for A4 size image.

CONNECTIONS

CONNECTION WITH USB INTERFACE

■ CONNECTING WITH A PERSONAL COMPUTER

- 1 Make sure to turn off **the** personal computer.
- 2 Connect this unit with **the** personal computer as following example.

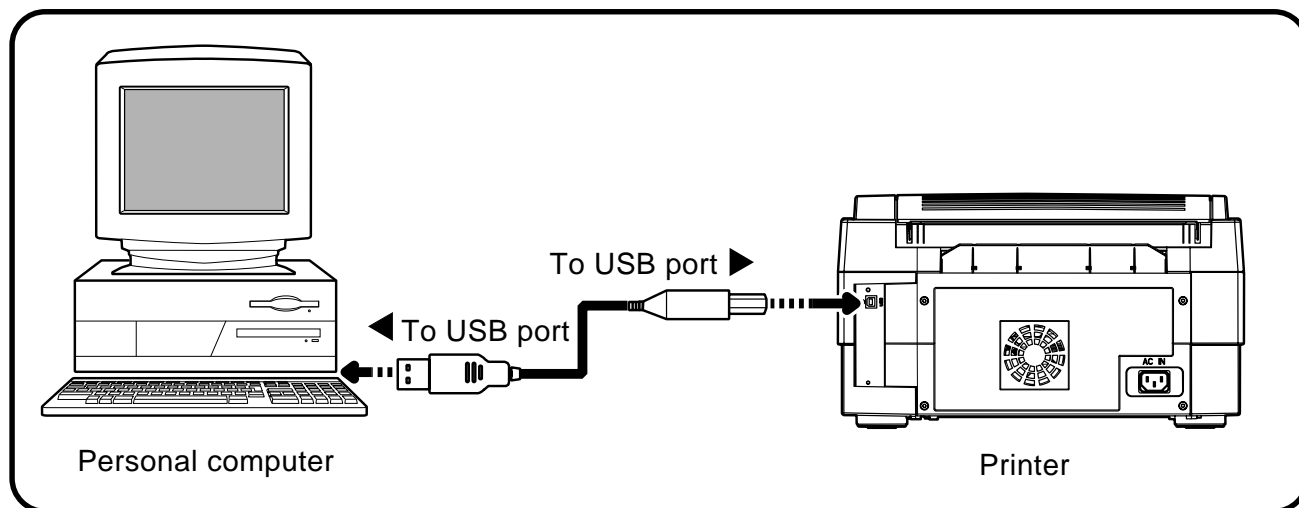

- 3 Connect **the** power cord.

■ Use **the** printer driver to **adjust** settings **for** the printer.

The printer driver is included in the CD-ROM. See page 15 for the details.

BEFORE OPERATION

Before printing,

1. Remove the shipping inserts on both sides of the paper tray inserting slot and the spacer inside the paper tray. (See below)
2. Install the ink cassette with the ink sheet installed. (page 11)
3. Install the paper tray with print paper installed. (pages 12-13)
4. Install printer driver.

PAPER SHEET SET

Make sure to use the following types of paper sheet and ink sheet set.

■ PAPER SHEET SET (Print paper and ink sheet)

Product name	Ink sheet size	No. of prints	Usage
CK3020L4P	A4 size	70 (35 sheets x 2 packs)	Surface-laminated colour print (glossy)
CK3020LL4P	Letter long size	60 (30 sheets x 2 packs)	Surface-laminated colour print (glossy)
CK3020L4PM	A4 size	70 (35 sheets x 2 packs)	Surface-laminated colour print (matte)
CK3020LL4PM	Letter long size	60 (30 sheets x 2 packs)	Surface-laminated colour print (matte)

REMOVING THE SHIPPING INSERTS

■ REMOVING THE SHIPPING INSERTS ON THE PAPER TRAY SLOT

- 1 Hold the tab on the shipping inserts and pull to the center.
- 2 Remove the other side of shipping inserts in the same way.

NOTE

Do not discard the shipping inserts. When you do not use the printer for a long period or transport this printer, make sure to attach the shipping inserts on the slot or the rollers may be deformed.

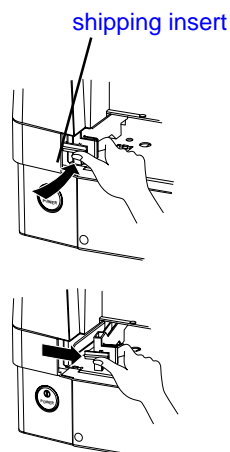

■ REMOVING THE SPACER FROM THE PAPER TRAY

- 1 Remove the cover on the paper tray.
- 2 Remove the spacer.

PRECAUTIONS

FEATURES

CONNECTIONS

PREPARATION

TROUBLE-SHOOTING

OTHERS

INSTALLATION OF INK SHEET

■ INSTALLATION OF INK SHEET

Install the ink sheet (option: supplied [with](#) paper sheet set) to the ink cassette before inserting the ink cassette into the printer.

1 Press **OPEN** button to open the top cover.

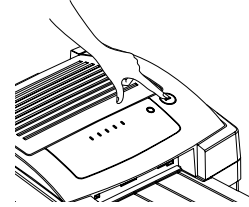

2 If necessary, push the old ink cassette to the left and lift it up to remove it.

NOTE

Images remain on the ink sheet after printing. If you are working with confidential documents, you may need to consider [alternative](#) ways of disposing of the ink sheet to maintain security.

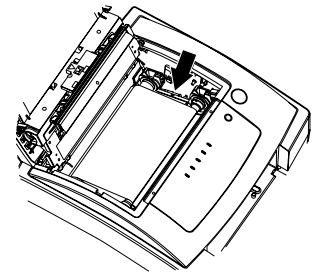

3 Remove old ink sheet from the ink cassette.

Do not discard the ink cassette. It can be used repeatedly.

4 Remove the new ink sheet from its packaging.

Touching the dye patches could contaminate the ink sheet, resulting in scratches on your prints.

5 Set the new ink sheet on the ink cassette as shown in the figure.

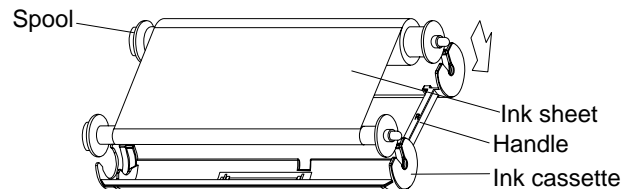

6 **Hold** the ink cassette by the handle, and slide the spool onto the 2 hubs on the left side.

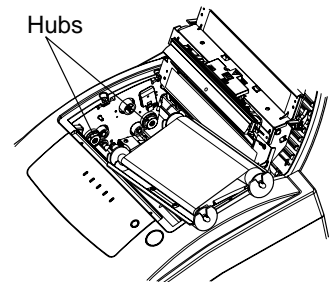

7 Push the ink cassette against the hubs on the left until it **engages with** the 2 holders on the right.

8 Turn the thick spool in the direction shown by the arrow, until the ink sheet is taut.

9 Close the top cover.

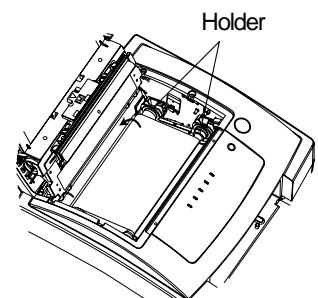

INSTALLATION OF PRINT PAPER

The paper tray adjusts to the size of the paper you are installing. Do not force paper that is too long or too wide into the tray.

NOTE

- Use only the tray designed for this printer.
- A spacer for protection during transport is attached inside the paper tray when the printer is shipped from the factory. Remove this spacer when using the printer.

1 Pull down the plate lever of the paper tray until you hear a click.

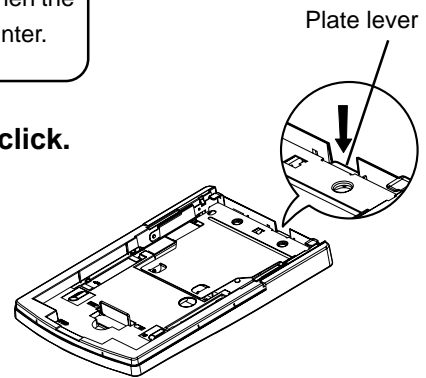

2 If necessary, adjust the paper tray to fit the paper you are installing.

Move the paper width adjuster and paper length adjuster according to the paper size you are installing. Move them as shown below.

paper size	Paper width adjuster	Paper length adjuster
A4	Raise	Raise
Letter long	Lay down	Lay down

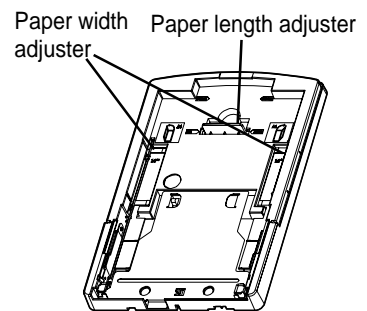

3 Take the print paper out of the packaging together with the cardboard for protecting the printing surface.

NOTE

- The paper may be stuck together. Loosen the pages well before unpacking.
- The cardboard is placed on the top of the print paper to protect the printing surface. Take the cardboard together with print paper so that you do not touch the printing surface.

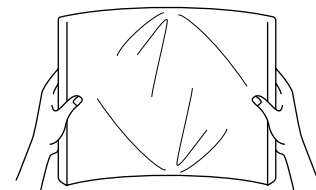

Loosen the paper before unpacking.

4 Place the paper in the tray with the cardboard on the top.

Make sure that the front corners of the stack are under the metal tabs.

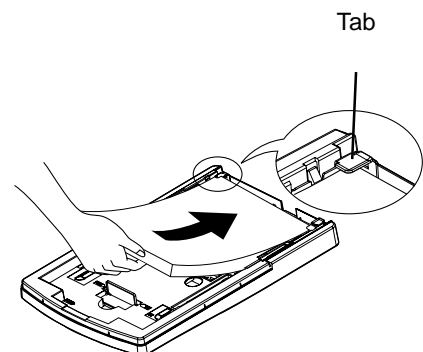

5 Remove the cardboard.

NOTE

- You can load only one pack of print paper supplied as paper sheet set. When adding the paper, take care not to exceed the red line on the paper tray. (50 sheets max.)

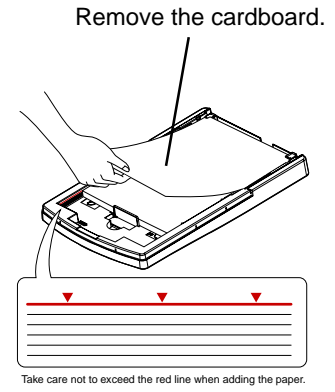

6 Set the paper cover onto the paper tray.

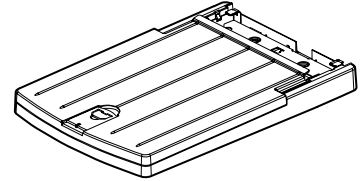

7 Install the paper tray in the printer.

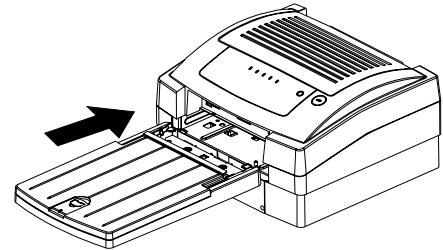

8 Raise the stopper.

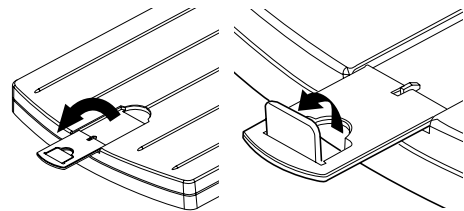

USAGE AND STORAGE OF PAPER SHEET SET

BEFORE PRINTING

- Fingerprints or dust on the paper's surface may degrade print quality and cause paper jams.
- When print paper is rapidly transferred from a cool place to a hot place, vapour or dew will be generated on the paper's surface causing paper jams or degraded print quality. Leave the print paper in the room to stabilize its temperature before [use](#).
- When print paper or ink sheet runs out during printing, the printing operation stops and the MEDIA indicator blinks. Set new ink sheet or print paper.
- Do not use wet or damaged paper. It may cause malfunction.
- Avoid touching or pulling the ink sheet with fingers. It may degrade the print quality.
- When the ink sheet is exhausted, replace it with a new one. Used ink sheet is not reusable.
- Do not open the print paper and ink sheet until [you are ready to use them](#).
- [The](#) paper sheet set is a combination of ink sheet and print paper. Use the combination provided in the box. If the combination is changed, malfunction may occur.

AFTER PRINTING

- When the printed paper is touched [with](#) a wet hand, the print may be discoloured.
- Fading may occur if the print-face is exposed to organic chemical agents which may affect print paper (e. g. alcohol, ester, ketone based).
- Fading will be accelerated upon contact with PVC-based materials (e. g. adhesive tapes, rubber erasers, etc.).
- Do not put a print back into the paper tray. Doing so can cause jams and loss of completed prints.
- Store prints in a cool, dry environment free of chemical contamination. Avoid exposure to high intensity light sources, particularly fluorescent light and sunlight, which are [high](#) in ultraviolet radiation.

STORAGE OF PAPER SHEET SET

- Leaving the print paper in contact with PVC-based materials causes [the](#) print paper to [discolour or become](#) stained.
- [Never store print paper close to heaters or in hot, humid or dusty places.](#)
Keep print paper in a place where;
Temperature : 5°C - 30°C (41°F - 86°F)
Humidity : 20% - 60%RH

PRECAUTIONS

FEATURES

CONNECTIONS

PREPARATION

TROUBLE-SHOOTING

OTHERS

INSTALLING PRINTER DRIVER

The printer driver is required to print the data from a personal computer connected with this unit. The printer driver for Windows® is supplied with this unit.

Product name	Operating conditions
CPD3020W	Applies for Microsoft®Windows®98 and Windows® Me
CPD3020N0	Applies for Microsoft®Windows® 2000 and Windows® XP

Refer to the “Read me” in the CD-ROM for installing the printer driver.

Windows®98, Windows®Me, Windows® 2000 and Windows® XP are the registered trademarks of Microsoft Corporation in the U.S.A. and other countries.

PRECAUTIONS

FEATURES

CONNECTIONS

PREPARATION

TROUBLE-
SHOOTING

OTHERS

TROUBLESHOOTING

INDICATION ON THE FRONT PANEL & COUNTERMEASURES

If for some reason printing is not possible or error occurs during printing, the indicators on the front panel will be lit. In this case, follow the procedure described below.

○: lit ☀: blinks ●: not lit

ALARM	MEDIA	DATA	READY	Causes	Countermeasures
●	☀	●	●	Paper is used up. Paper is not installed. The ink sheet is not installed.	<ul style="list-style-type: none"> • Install a new set of paper. Refer to pages 12-13. • Replace the ink sheet with a new one. Refer to page 11.
○	○	●	●	The wrong type of ink sheet is installed. Print paper is not specified by the printer driver. The ink sheet and the print paper are not combined correctly.	<ul style="list-style-type: none"> • Use the correct ink sheet for the installed paper. • Use the specified print paper. • Use them in the correct combination.
○	●	●	●	The top cover is open.	<ul style="list-style-type: none"> • Close the top cover.
●	●	● (*Note)	☀	The temperature of the thermal head has become too high.	<ul style="list-style-type: none"> • Wait until the indicator goes off.
☀	☀	●	●	Paper jam occurs.	<ul style="list-style-type: none"> • Refer to page 18 "Overcoming paper jams". If the status is not improved by carrying out this measure, consult your dealer.
☀	●	●	●	Mechanical error occurs.	<ul style="list-style-type: none"> • Remove the paper tray. Turn off the power and then turn on it again. After that, install the paper tray.

*Note : DATA indicator blinks during data transferring.

PRECAUTIONS

FEATURES

CONNECTIONS

PREPARATION

TROUBLE-SHOOTING

OTHERS

BEFORE CALLING FOR SERVICE

- Use the following troubleshooting chart to try to resolve any apparent defect in operation. If you are unable to resolve the problem, unplug the power cord and contact your dealer.

Symptom	Check and Remedy
No power (when POWER lamp does not illuminate)	Is the power cord plug disconnected from the outlet? →Connect the power cord plug to the outlet firmly. After turning the power off, wait for approx. 2 minutes. Then turn on the power.
The image is not printed.	Is the cable connected correctly? Is the image data sent to this printer? Is the print paper or ink sheet used up? →Check the status.
The paper is not fed.	Is the combination of the paper size installed and paper tray setting correct? Is the print paper used up? Are too many print paper sheets installed in the paper tray? →Check the status.
The stored image in the memory cannot be enlarged to fill the maximum print area.	Is the appropriate image data transferred? →Check the status.
White or coloured lines or scratches appear on the printed image.	Is there any dirt on the print paper or ink sheet? →Replace print paper and ink sheet with new one. Is the thermal head dirty? →Clean up the thermal head. (See page 20 for cleaning.)
Smudges, smears and fingerprints appear on the printed image.	Are there any fingerprints, grease or oil on the paper or ink sheet ? →Replace print paper and ink sheet with new one.

PRECAUTIONS
FEATURES
CONNECTIONS
PREPARATION
TROUBLE-SHOOTING
OTHERS

OVERCOMING PAPER JAMS

■ CLEARING A PAPER JAM FROM THE INK CASSETTE AREA

1 Press **POWER** button to turn off the printer.

2 Press **OPEN** button to open the top cover.

3 Remove the ink cassette.

Push the ink cassette to the left and **lift up to remove**.

4 Pull out the jammed paper.

Do not touch the thermal head right after printing as it is hot. Touching it may cause a burn or injury.

5 Install the ink cassette.

NOTE

Do not put partially-fed paper back into the paper tray. Discard any partially-fed paper from the paper tray.

■ CLEARING A PAPER JAM FROM THE FRONT AREA

1 Press **POWER** button to turn off the printer.

2 Remove the paper tray.

3 Pull out the jammed paper.

4 Install the paper tray.

When installing the paper tray, make sure to pull down the plate lever of the paper tray until you hear a click.

NOTE

Do not put partially-fed paper back into the paper tray. Discard any partially-fed paper from the paper tray.

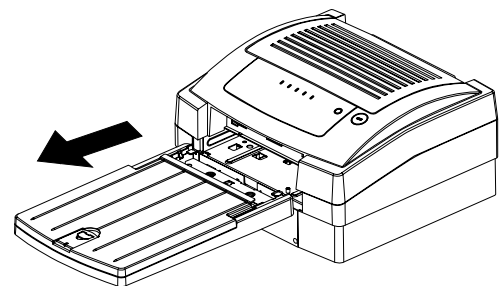
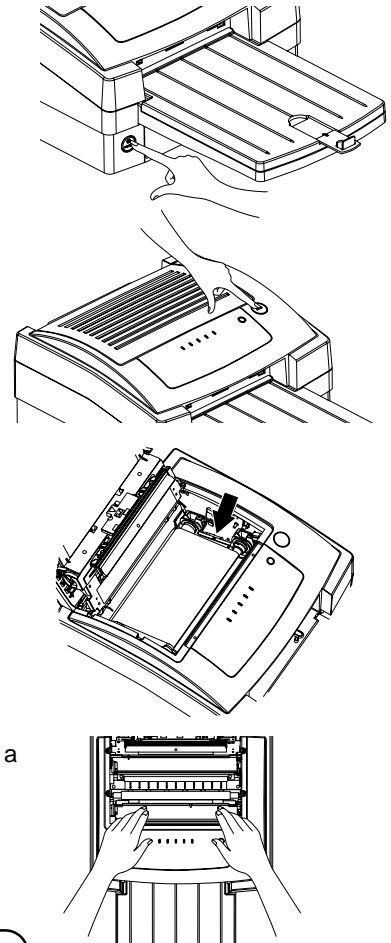

REPAIRING A TORN INK SHEET

- 1 Position the ink cassette with the torn ink sheet on a **flat, clean surface**.
- 2 Place a piece of office tape on the center of the ink sheet.

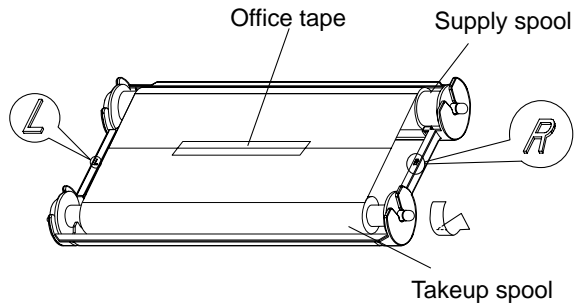

- 3 Wind the takeup spool counterclockwise so that the office tape is not seen and the ink sheet is straight.
- 4 Install the repaired ink cassette in the printer.

PRECAUTIONS

FEATURES

CONNECTIONS

PREPARATION

TROUBLE-
SHOOTING

OTHERS

CLEANING

Cleaning as indicated below will help maintain stable printer operation and extend the printer's life.

Preparations

- Alcohol (isopropyl alcohol)
- Tissue paper (Fold in half about 4 times, and use the folded side to clean.)
- Cotton buds
- Cleaning kit (Option)*

Other : Cleaner pen (Option)*

*Please ask the dealer about options.

Make sure to turn off the power before cleaning.

1 Turn off the power and press OPEN button to open the top cover.

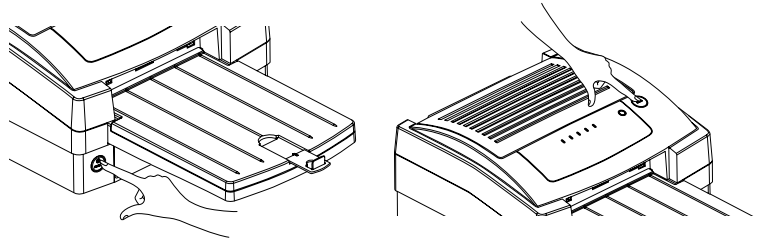

2 Use a cloth or tissue paper moistened with alcohol to clean the thermal head, and wipe along the heater line three or four times.

- Wipe the full length of the area (always in **one** direction).
- Use a clean part of the cloth or tissue paper for each wipe.
- Apply firm, even pressure.
- Wipe only the areas shown right.

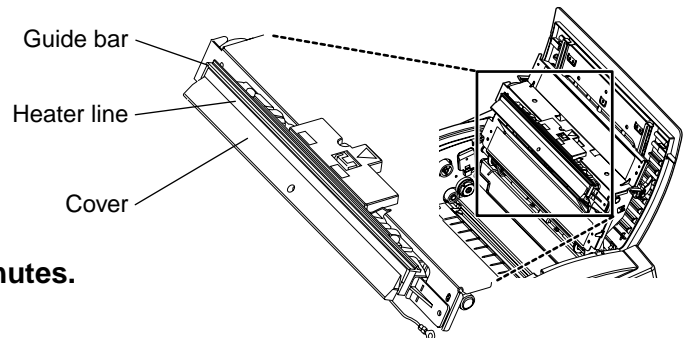

3 Allow the wiped area to dry for about two minutes.

4 Close the top cover, and turn on the power.

5 If image quality **problems are still** visible on the print, repeat steps 1 - 4.

NOTE

- Do not damage the thermal head.
- When the **poor print quality is not corrected even if the head has been cleaned**, **replacement of the thermal head may be** required. Contact your dealer.
- **The thermal head is hot directly** after printing. Wait until the head cools **before cleaning** the thermal head.

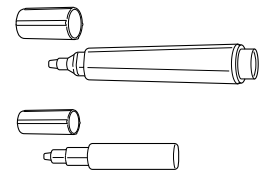
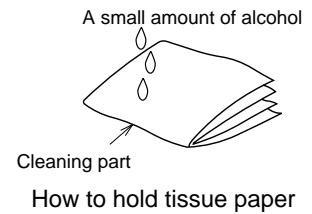

SPEC & OPTIONS

SPECIFICATIONS

Class	Digital colour printer		
Model	CP3020DE		
Printing method	Thermal Dye Sublimation 3 colour faces progressive printing (yellow, magenta and cyan) and surface lamination		
Print quality	Dot resolution	Max. 3134 x 2508 pixels (A4 size)	
	314 PPI	Max. 3762 x 2508 pixels (Letter long size) PPI : Pixels Per Inch	
Number of grades	256 (8 bits) for each colour (About 16.7 million colours)		
Printing time	A4 size	Approx. 77 sec./sheet (glossy)	
	Letter long size	Approx. 90 sec./sheet (glossy)	
Ink sheet	Special cartridge method		
Print paper	Special cut paper	A4 size 297 x 210mm	Printing area 253.9 x 203.2mm
		Letter long size 355.6 x 215.9mm	Printing area 304.8 x 203.2mm
Supply method	Automatic (cut paper)		
Interface	USB Ver1.1		
Power supply	AC220-240V, 50/60 Hz		
Power consumption	1.35A (AC220-240V, 50/60 Hz) during printing (0.2A when not printing)		
Installation conditions	Temperature	: 5°C - 35°C (41°F - 95°F)	
	Humidity	: 30% - 80% (No dewing)	
Operation altitude	Within Horizontal ±5°		
Outside dimensions	402(W) x 231(H) x 378(D) mm		
Weight	14kg (without paper tray)		
Accessories	Power cord (1), Ink cassette (1), Paper tray (1), CD-ROM (1), Quick setup guide (1)		

■ Contents of CD-ROM

- Operation manual
- Printer driver
- ReadMe

OPTIONS

■ PAPER SHEET SET

Product name	Ink sheet size	No. of prints	Usage
CK3020L4P	A4 size	70 (35 sheets x 2 packs)	Surface-laminated colour print (glossy)
CK3020LL4P	Letter long size	60 (30 sheets x 2 packs)	Surface-laminated colour print (glossy)
CK3020L4PM	A4 size	70 (35 sheets x 2 packs)	Surface-laminated colour print (matte)
CK3020LL4PM	Letter long size	60 (30 sheets x 2 packs)	Surface-laminated colour print (matte)

PRECAUTIONS

FEATURES

CONNECTIONS

PREPARATION

TROUBLE-
SHOOTING

OTHERS

Mitsubishi Electric Europe B.V.

UK Branch

Travellers Lane, Hatfield, Herts. AL10 8XB, England, U.K.

Phone (0) 1707 276100 FAX (0) 1707 [278541](tel:1707278541)

German Branch

Gothaer Strasse 8, 40880 Ratingen ; Postfach 1548, 40835 Ratingen ; Germany

Phone (2102) 486-9250 FAX (2102) 486-7320

French Branch

25, Boulevard des Bouvets - 92741 NANTERRE cedex

Phone (01) 55.68.55.00 FAX (01) 55.68.57.31

Italian Branch

Centro Direzionale Colleoni, Palazzo Perseo-Ingresso 2,

Via Paracelso 12, 20041 Agrate Brianza, (Milano) Italy

Phone (039) 60531 FAX (039) 6057694

Benelux Branch

Nijverheidsweg 23 A, 3641 RP. Postbus 222, 3640 AE Mijdrecht

Phone 02972-82461 FAX 02972-83936

Spanish Branch (Barcelona)

Sucursal en españa

Ctra. de Rubí, 76-80 - Apdo. 420

08190-Sant Cugat del Vallés - (Barcelona) Spain

Phone 93.5653154 FAX 93.5894388

Manufactured by Mitsubishi Electric Corporation
1 Zusho Baba, Nagaokakyo-city, Kyoto Japan