



DIGITAL COLOR PRINTER

MODEL

CP770DW

OPERATION MANUAL

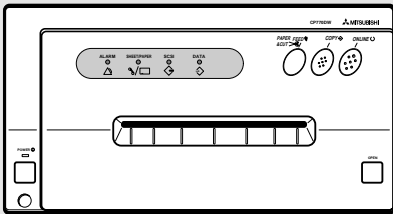

THIS OPERATION MANUAL IS IMPORTANT
TO YOU.
PLEASE READ IT BEFORE USING YOUR
DIGITAL COLOR PRINTER.

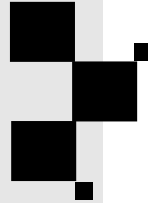

DIGITAL COLOR PRINTER

This digital colour printer complies with the requirements of the EC Directive 89/336/EEC, 73/23/EEC, 93/42/EEC and 93/68/EEC.

The electro-magnetic susceptibility has been chosen at a level that gains proper operation in residential areas, on business and light industrial premises and on small-scale enterprises, inside as well as outside of the buildings. All places of operation are characterised by their connection to the public low voltage power supply system.

INFORMATION

This Class A digital apparatus complies with Canadian ICES-003.

Cet appareil numérique de la classe A est conforme à la norme NMB-003 du Canada.



“CLASSIFIED BY UNDERWRITERS LABORATORIES INC.® WITH RESPECT TO ELECTRIC SHOCK, FIRE AND MECHANICAL HAZARDS ONLY IN ACCORDANCE WITH UL 2601-1 AND CAN/CSA C22.2 NO. 601.1.”

According to Clause 5 in UL 2601-1 sec 6.8.1, this unit is classified by the followings;

- The type of protection against electric shock:
EQUIPMENT energized from an external electrical power source:
CLASS I EQUIPMENT
- The degree of protection against electric shock:
TYPE B EQUIPMENT
- The degree of protection against harmful ingress of water:
Ordinary EQUIPMENT (enclosed EQUIPMENT without protection against ingress of water)
- The degree of safety of application in the presence of a FLAMMABLE ANAESTHETIC MIXTURE WITH AIR or WITH OXYGEN OR NITROUS OXIDE:
EQUIPMENT not suitable for use in the presence of a FLAMMABLE ANAESTHETIC MIXTURE WITH AIR or WITH OXYGEN OR NITROUS OXIDE
- The mode of operation:
CONTINUOUS OPERATION



TYPE B EQUIPMENT

WARNING :

TO PREVENT FIRE OR SHOCK HAZARD, DO NOT EXPOSE THIS APPLIANCE TO RAIN OR MOISTURE.

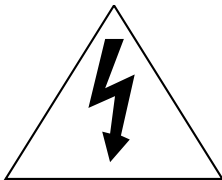
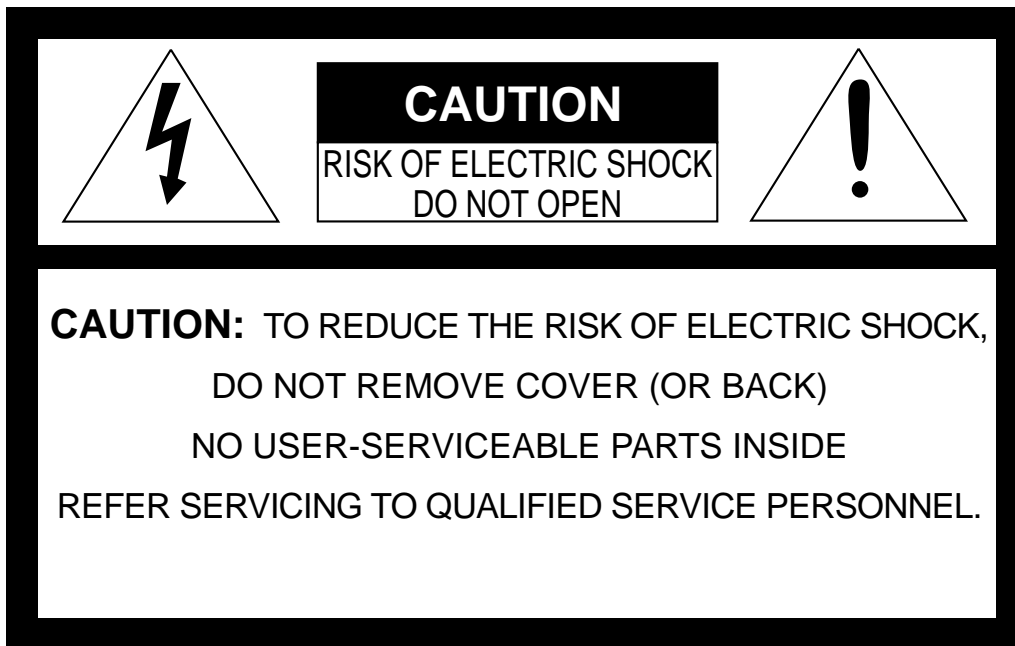

The lightning flash with arrowhead symbol, within an equilateral triangle, is intended to alert the user to the presence of uninsulated "dangerous voltage" within the product's enclosure that may be of sufficient magnitude to constitute the risk of electric shock.



The exclamation point within an equilateral triangle is intended to alert the user to the presence of important operating and maintenance (servicing) instructions in the literature accompanying the appliance.

NOTE:

This equipment has been tested and found to comply with the limits for a Class A digital device, pursuant to Part 15 of the FCC Rules. These limits are designed to provide reasonable protection against harmful interference when the equipment is operated in a commercial environment. This equipment generates, uses, and can radiate radio frequency energy and, if not installed and used in accordance with the instruction manual, may cause harmful interference to radio communications. Operation of this equipment in a residential area is likely to cause harmful interference in which case the user will be required to correct the interference at his or her own expense.

WARNING:

Use the included AC power cord so as not to interfere with radio and television reception. If you use other cables, it may cause interference with radio and television reception.

CONTENTS

Contents	1
Safety precautions	2-4
Special features	5
Unpacking	6
Features and functions	7-8
Front panel	7
Inside of printing unit	8
Rear panel	8
Connections	9-14
Connection with parallel data interface	9-10
Parallel data signal	11-13
Connection with SCSI data signal equipment	14
Before operation	15-20
Paper sheet set and ink sheet	15
Removing transport screw and protective cushion	15-16
Installation of print paper	16-17
Installation of ink sheet (For color print)	18
Usage and keeping of paper sheet set	19
Installing printer driver	20
Troubleshooting	21-23
Indication on the front panel & countermeasures	21
Overcoming paper jams	22
Before calling for service	23
Cleaning	24-25
Spec & options	26-27

PRECAUTIONS

FEATURES

CONNECTIONS

PREPARATION

TROUBLE-SHOOTING

OTHERS

SAFETY PRECAUTIONS

In the interest of safety, please observe the following precautions:

POWER REQUIREMENT

This product is designed for operation on 100-120V AC or 220-240V AC 50/60Hz AC. Never connect to any outlet or power supply having a different voltage or frequency.

WARNING: THIS APPARATUS MUST BE GROUNDED.

AVERTISSEMENT: CET APPAREIL DOIT ETRE MIS A LA TERRE.

PROTECTIVE MEASURES

IF ABNORMALITIES ARISE,

If the printer emits smoke or abnormal sounds, immediately unplug the power cord from the printer or power outlet. Continued use is dangerous. Contact your dealer about having the printer checked and serviced.

NEVER INSERT ANY OBJECT INTO THE UNIT

Nothing other than supplies for this printer should ever be inserted into the printer. Other items can cause a safety hazard and extensive damage to the mechanism and electronics.

DO NOT SET HEAVY OBJECTS ON TOP OF THE UNIT

Heavy objects can damage the unit and/or cause misoperation.

AVOID DAMAGING THE POWER CORD

Do not set anything heavy on the power cord nor allow it to become pinched, or cut. If the power cord becomes damaged, replace it immediately to avoid shock hazard or electrical fire.

When the power cord is replaced, use the same type as originally supplied, it is designed to reduce interference to radio & TV reception.

When unplugging the power cord, hold the plug, and remove it carefully.

KEEP THE UNIT DRY - DO NOT PLACE WATER OR OTHER LIQUID CONTAINERS, FLOWER VASES/POTS ON TOP OF THE UNIT

Liquids which get into the unit can cause serious damage to the unit and potential shock or fire danger. If liquid is spilled into or seeps into the unit, unplug the Power Cord immediately and seek service as soon as possible to avoid additional or possible damage due to corrosion.

"In the interest of safety, avoid handling of liquids near the unit."

DO NOT REMOVE THE CABINET. THERE ARE NO USER SERVICEABLE PARTS INSIDE AND YOU WILL EXPOSE YOURSELF TO HAZARDOUS VOLTAGES AND/OR YOU MAY CAUSE DAMAGE TO THE UNIT.

Touching internal parts is dangerous, and may cause a malfunction. Contact your dealer to carry out internal checks and adjustments. Disconnect the power cord before opening the cover to clear a paper jam, etc.

UNPLUG THE POWER CORD DURING A LONG ABSENCE OR DURING A ELECTRICAL STORM

Turn off the Main Power switch and unplug the power cord during a long absence or during a electrical storm.

WHEN SHIPPING OR TRANSPORTING THE UNIT

Always use the protective cushion and transport shipping screw to avoid damage to the printer during shipping or transportation. Remove the ink sheet cartridge and paper from the mechanism, and insert the protective cushion into the ink sheet cartridge area. Remove the mechanism transportation screw from the rear panel and secure the mechanism at the bottom with the screw.

BE CAREFUL AROUND PRINT PAPER EXIT SLOT

Do not insert your fingers or any object into the paper slot during printing.

Do not touch the cutter blade inside the paper exit slot, it can cause injury.

DO NOT TOUCH THE THERMAL HEAD

It becomes hot during printing and may remain hot for a time, causing injury. Oils, salts and moisture from your hands will contaminate the head and may spoil the prints.

BE CAREFUL WITH THE PRINTING MECHANISM

Do not move the printer while the printing mechanism is slid out. This may cause injury. Be careful not to catch your fingers in the printing mechanism when sliding the mechanism back into the normal closed position.

CONNECTION CABLES

Use the power cord supplied with the printer. The composite video input and output accepts standard 75 ohm BNC connection cables, and standard S-Video cables for separated Luminance & Chroma video. When connecting the unit to a computer with RS-232C interface, use a null modem cable.

INSTALLATION LOCATIONS

MAINTAIN GOOD VENTILATION

Ventilation slots and holes are provided on the rear, sides and bottom of this unit. Place the unit on a hard and level surface and locate at least 4 inches (10.16 cm) from walls to insure proper ventilation. When installing the unit in a system rack, leave space between the unit and the back of the rack.

UNSUITABLE LOCATIONS

Avoid installing the printer in unstable locations with high vibration or in hot-springs areas where hydrogen sulfide and acidic ions are likely to be generated.

PLACES WITH HIGH HUMIDITY AND DUST

Do not place the unit in locations with high humidity and dust. They can cause extensive damage. Avoid places where unit is likely to be exposed to oily fumes and vapours.

PLACES NOT LIKELY TO BE EXTREMELY HOT

Places exposed to direct sunlight, or near heating appliances can attain extremely high temperatures which may deform the cabinet, or cause other damage.

PLACE THE UNIT ON A HORIZONTAL SURFACE

The unit is likely to be affected if it is operated tilted, inclined or in unstable places.

PROTECT AGAINST DEW FORMATION

When the unit is moved from a cold area into a warm area, moisture can condense inside the unit and prevent operation. Allow the temperature to stabilize before use.

OPERATING AMBIENT TEMPERATURE RANGE

The operating temperature range is 41°F - 104°F (5°C to 40°C) and humidity of 20 - 80%. When using the unit in a system rack, make sure that the temperature inside the rack does not exceed this range.

FOR LONG OPERATING LIFE

UNSUITABLE MATERIALS FOR THE PRINTER

Paint coat flaking and plastic deformation are likely to occur if the unit is wiped with chemical dusters, benzine, thinner or any other solvent, if rubber or PVC items are left in contact with the unit for a extended period, or if the unit is sprayed with insecticide.

CARE OF THE CABINET

Unplug and clean with a soft cloth slightly moistened with a mild soap and water solution. Allow to dry completely before operating. Never use petroleum base solutions or abrasive cleaners.

HEAD ABRASION

The thermal printhead, like the video head, wears out. When it is worn, it becomes hard to print out fine details of the picture. Then it is necessary to replace the thermal head. Consult your dealer about having the head replaced.

SAFETY PRECAUTIONS

CONNECTING DEVICES

Read thoroughly the Safety Notices, Cautions and "Operating Precautions" of the instruction booklets for the other devices connected with the unit.

CAUTION ON RELOCATING

When transporting this unit, make sure it is not likely to be subjected to impacts. They can be a primary cause for damage. Always use the mechanism protective cushion and the transport shipping screw when shipping the unit. Before moving the unit, make sure to disconnect the power cord from the power outlet, and the cables from the connected devices.

SAFETY CHECKS

- Periods: According to the recommendations of the manufacturer of medical device.
- Scope: a) Visual inspection
Housing, leads, controls, displays, labels/ markings, accessories, operation manual.
- b) Functionality test
Testing of functions (according to operation manual) as well as compatibility and usability of device and accessories.
- c) Electrical test
Testing of electrical safety of the system according to EN60601-1.

High humidity or dust

Avoid locations with high humidity and dust in order to avoid malfunctioning of the device.

Also avoid locations subject to corrosive gasses and smoke.

Heat

Direct sunlight, heaters or other heat sources may deform the housing and subsequently cause malfunctioning.

TECHNICAL DESCRIPTION

The supplier will make available on request such circuit diagrams, component part lists, descriptions, calibration instructions or other information which will assist the USER's appropriately qualified technical personnel to repair those parts of the EQUIPMENT which are classified by the manufacturer as repairable.

The use of ACCESSORY equipment not complying with the equivalent safety requirements of this equipment may lead to a reduced level of safety of the resulting system. Consideration relating to the choice shall include:

- use of the accessory in the PATIENT VICINITY
- evidence that the safety certification of the ACCESSORY has been performed in accordance to the appropriate EN60601-1 and/or EN60601-1-1 harmonized national standard.

The transportation and storage environmental conditions are:

Temperature : -20°C - +60°C (-4°F - +140°F)

Humidity : 90%RH or less at 40°C(104°F)

Note : The above transportation environmental conditions indicate the storage environmental conditions during transport.

OTHER CAUTIONS

Dust or other foreign matter adhering to the print paper or the sheet cartridge, or deformation resulting from exposure to extremely low or high temperatures could cause loss of color, uneven color or lines, or wrinkles in the print images.

If there is noise or vibration in a VCR still image or other playback picture, the printed image may be distorted or the upper part of the image may be crooked. For best results with VCR playback, memorize the desired image in normal play and use the Field mode for printing if there is rapid movement in the picture.

NOTE:

MEMORIZED IMAGES ARE STORED IN VOLATILE MEMORY AND MAY BE LOST IN THE EVENT OF POWER FLUCTUATION OR MALFUNCTION.

As for paper sheet set, refer to Page 15, "Paper sheet set and ink sheet".

This product is to be employed with medical equipment, just for reference purpose, not for medical diagnostic purpose.

SPECIAL FEATURES

SPECIAL FEATURES

2 PRINT SIZES ARE AVAILABLE ACCORDING TO THE PURPOSE

2 printing sizes, L size (max.130 x 104.8 mm) and S size (max.104.8 x 75 mm), are selectable.

HIGH SPEED PRINTING

Printing speed is approx.19 seconds (in S size print). Using a roll paper shortens the time for installing and removing.

LARGE CAPACITY OF PRINTING

Maximum number of printing (S size) is 200 printings per a roll paper. The large capacity of roll paper printing reduces a time of exchanges.

POSSIBLE OF HIGH QUALITY PRINTING

High quality print is available in sublimation dye thermal method which is superior in repeatability of images. It also employs 256 gradients and about 16,700,000 colors in each YMC.

325 PPI HIGH RESOLUTION

325 PPI high resolution clears the image data. Precise illustrations and photo images can be printed sharply.

MULTI AND WIDE PRINT FOR VARIOUS DEMANDINGS

4 and 16 images of multi print and wide print are available. Several multi print modes and wide print modes are selectable according to the demanding.

WIDE COMPATIBILITY WITH A VARIETY OF INTERFACE AND SYSTEMS

- (1) High speed transferring by the centronics interface which corresponds to IEEE1284
- (2) Input and output control signals from SCSI II interface (Optional).
- (3) Shortening time of PC processing from the newly developed driver.
- (4) Compatible with the former VCP of CP700DU(DE) and CP700DSU(DSE).

PRECAUTIONS

FEATURES

CONNECTIONS

PREPARATION

TROUBLE-
SHOOTING

OTHERS

UNPACKING

UNPACKING

Take the unit out of the box by the following procedures. Make sure to check the contents.

1 Open the top of the box.

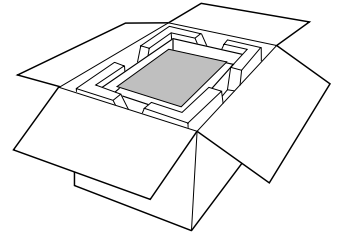

2 Remove the accessory box.

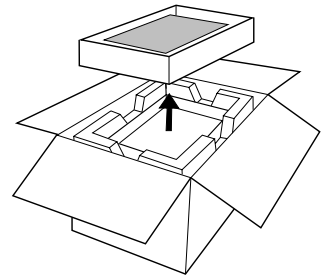

3 Remove the cushion above the unit.

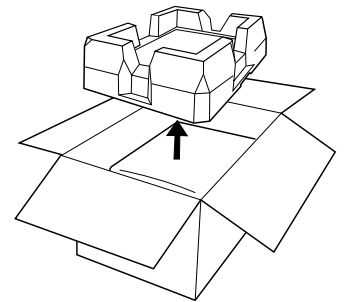

4 Take the unit out of the box carefully.
Make sure to keep the unit horizontally.

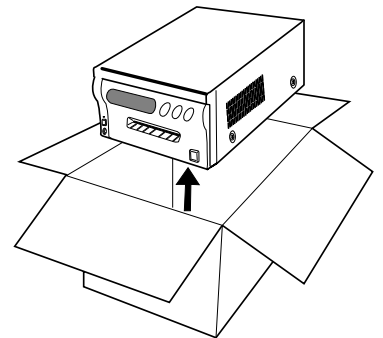

■ CONTENTS OF THE ACCESSORY BOX

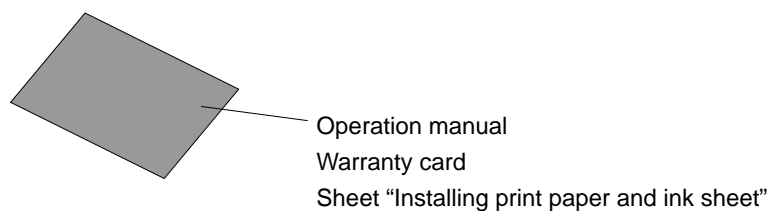
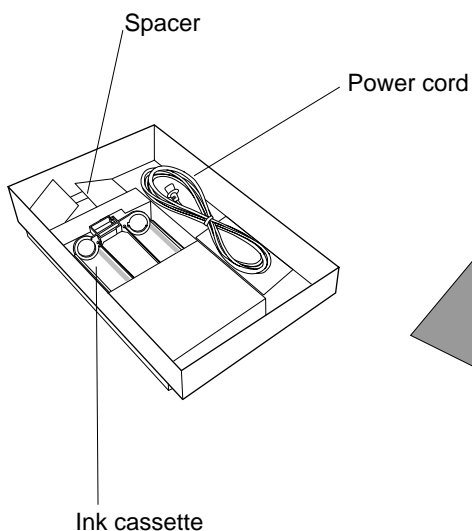

FEATURES & FUNCTIONS

FRONT PANEL

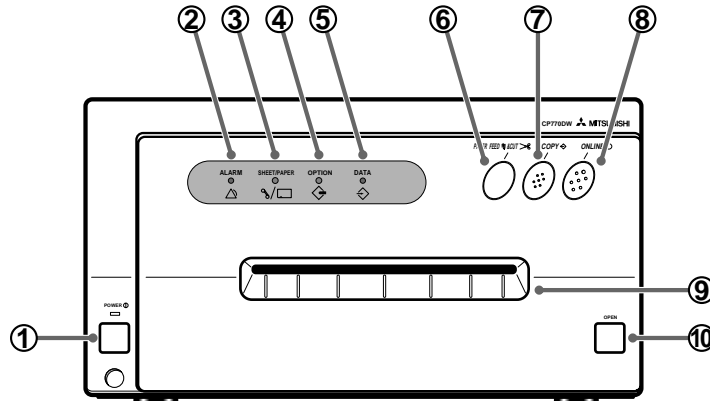

① POWER BUTTON

Press to turn on power. Press again to turn off power. When the power is turned on, the lamp above this button illuminates.

② ALARM LAMP

When this unit is overheated, this lamp goes on and off. When other error occurs, it illuminates. See page 21.

③ SHEET/PAPER LAMP

Illuminates when ink sheet or print paper is used up or any trouble occurs in the sheet cartridge or print paper.

④ OPTION LAMP

Illuminates when signal is inputted through the optional SCSI terminal.

⑤ DATA LAMP

Goes on and off during transferring data.

⑥ PAPER FEED & CUT BUTTON

Pressing this button, the print paper is fed and cut. When ⑧ ON LINE lamp is lit, this button is not functional.

⑦ COPY BUTTON

When pressing this button, the transferred data will be printed. When ⑧ ON LINE lamp is lit, this button is not functional.

⑧ ON LINE BUTTON

Press to switch the PC connection between on and off line. When on line is selected, you can control this unit through PC. When on line is selected, this lamp illuminates. Press again to select off line (The lamp will be turn off).

⑨ PRINT OUTLET

The printed paper comes out here.

⑩ OPEN BUTTON

Press to slide out the printing mechanism. Open the mechanism to load paper and ink or to clear a paper jam.

INSIDE OF PRINTING UNIT

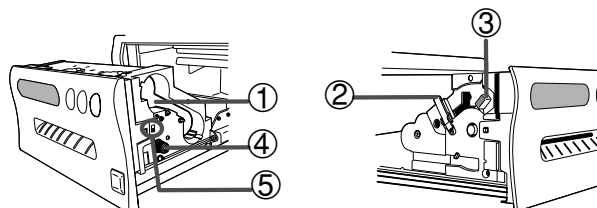

① INK CASSETTE COMPARTMENT

Load the cassette with ink sheet.

② INK CASSETTE LOCKING LEVER

Push this lever to take the ink cassette out.

③ PAPER RELEASE LEVER

Move this lever up or down when inserting print paper.

④ PAPER SENDING CONTROL

Turn this control clockwise to rewind the print paper.

⑤ SLIDE SWITCH

Selects the input terminal between PARALLEL and OPTION(SCSI).

The default setting is OPTION(SCSI).

REAR PANEL

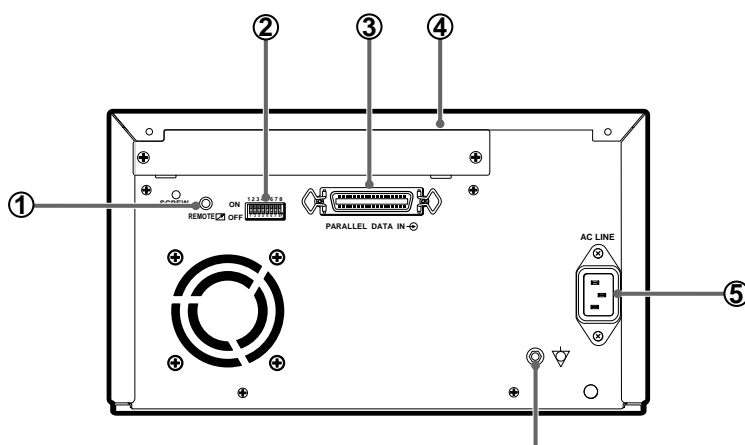

Potential equalization connector

This is used to equalize the potential of the equipment connected to the unit.

For details, refer to the installation instruction of the equipment to be connected.

① REMOTE TERMINAL

This terminal is not available.

Do not use this terminal, except qualified service personnel.

② MODE SWITCHES

Used to set the various functions of this unit. See page 9.

③ PARALLEL DATA IN PORT

Use these terminals to connect this unit to a device equipped with parallel data interface such as personal computer.

To prevent leakage of electricity, keep the attached protective cover onto the terminal, when not connecting the cable. When using the optional SCSI board terminals, fix the protective cover with the plate and screw which are attached to the optional board (SB770).

See pages 11-13 for connection.

④ OPTIONAL SCSI BOARD SLOT

Insert the SCSI board sold separately to this slot. See the instruction manual for SCSI board SB770.

⑤ AC LINE SOCKET

Connects to the provided power cord. Insert the cord firmly.

CONNECTIONS

The unit is compatible with each of the following input signals.

- Parallel data signal : for Centronics compatible Parallel data interface
- SCSI data signal : Refer to the operation manual of the optional SCSI board.

“Centronics” is a registered trademark of Centronics Data Corporation.

CONNECTION WITH PARALLEL DATA INTERFACE

CONNECTING WITH PC (EXAMPLE)

Connect this unit with Personal computer as following example.

Make sure to turn off the power of the unit and the connecting equipment before connection.

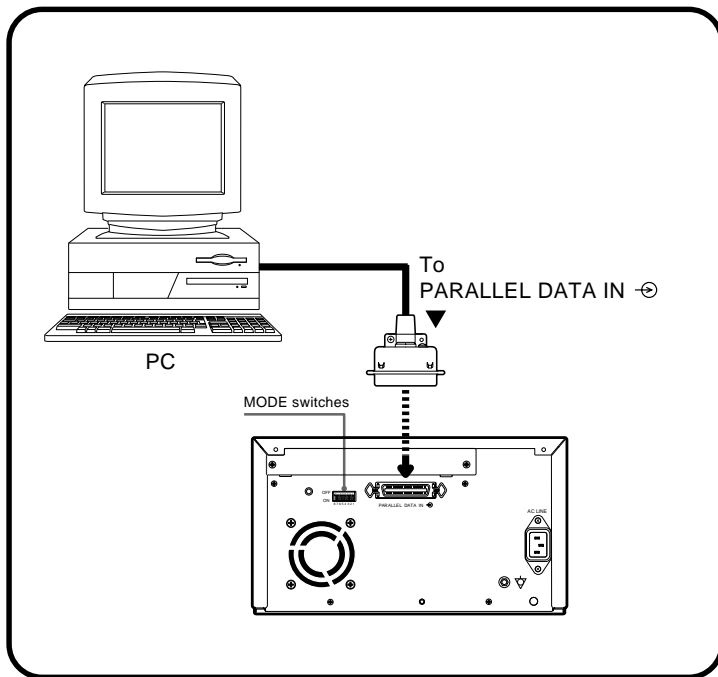

- 1 Connect the unit with PC through parallel cable.
- 2 Set the slide switch in the printing unit to “PARALLEL”.

SETTING MODE SWITCHES

Set the mode switches (DIP-SW) on the rear panel.

- All the switches are set to OFF as shown right when shipping.
- Set the mode switches No. 1 and 2 according to the printer driver to be used.
 - Set to Standard mode when using the printer driver supplied with this unit.
 - Set to Compatible mode when using printer drivers (CPD-04/CPD-05) for CP700DU/DE and CP700DSU/DSE.

No. 1	No. 2	Mode
OFF	OFF	Standard mode
ON	OFF	Compatible mode (fine print)*
ON	ON	Compatible mode (standard print)*
OFF	ON	Unused

* Refer to “Read me” of the supplied printer driver for the detail of “fine print” and “standard print”.

- With the mode switch No. 4, set the mirror print.
 - OFF Normal print
 - ON Mirror print
- With the mode switch No. 5, set the HX mode.
 - OFF HX mode off
 - ON HX mode on

When using print paper, CK700L4P(HX) or CK700S4P(HX), set this switch to ON.
Do not use other print paper or ink sheet for this setting. The unit may be damaged.
- Set the mode switches No. 3, 6, 7 and 8 to OFF.

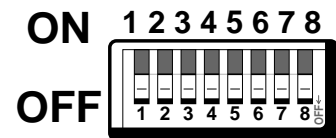

PRECAUTIONS

FEATURES

CONNECTIONS

PREPARATION

TROUBLE-SHOOTING

OTHERS

CONNECTIONS

■ SETTING ON LINE STATUS

- 1 Press **POWER** button to turn on this unit.
 - The lamp above the POWER button is lit.
- 2 Turn on the power of the personal computer connected.

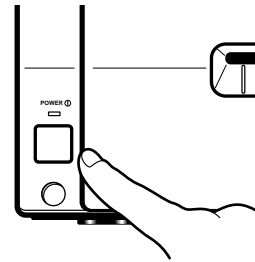

- 3 Confirm that the **ON LINE** button on the front panel is lit.
 - When ON LINE is selected, the lamp illuminates.

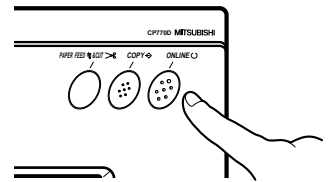

NOTE

When ON LINE lamp is already illuminating, the operation on this page is not necessary. In the following conditions, ON LINE lamp illuminates when turning on the power.

•Installing printing paper and ink sheet.

+

•Inserting printing unit correctly.

+

•Available to receive the data.

CONNECTIONS

- Parallel input connector port Signal allocation (Signal : Nibble)

Pin No.	Return pin No.	Signal	From/To	Function
1	19	HostClk	PC/VCP	High
2 - 9	20 - 27	Unknown	PC/VCP	Unknown
10	28	PtrBusy	PC/VCP	Sends data in "Low" when HostBusy is "Low". After HostBusy turns "High", this signal becomes "High".
11	29	PtrBusy	PC/VCP	Data4, Data8 (MSB)
12		AckDataReq	PC/VCP	Data3, Data7
13		Xflag	PC/VCP	Data2, Data6
14		HostBusy	PC/VCP	High : VCP is on BUSY status. Low : VCP can send data.
16 • 17		GND		Earth
18		High	PC/VCP	PeripheralLogicHigh
19 - 30		GND		Earth
31	16	$\overline{\text{Init}}$	PC/VCP	Clears sending data to this unit. (Low) Incoming pulse width should be 100 μ s minimum.
32		$\overline{\text{DataAvail}}$	PC/VCP	Data1(LSB), Data5
15 • 33 - 35		NC		Unused
36		1284 Active	PC/VCP	Becomes "High" when VCP requests each mode of IEEE1284.

- Parallel input connector port Signal allocation (Signal : ECP)

Pin No.	Return pin No.	Signal	From/To	Function
1	19	HostClk	PC/VCP	Forward data transfer : Becomes "Low" when PeriphAck is "Low" and there is data to be read. Returns to "High" when PeriphACK becomes "High".
2 3 4 5 6 7 8 9	20 21 22 23 24 25 26 27	DATA1 (LSB) DATA2 DATA3 DATA4 DATA5 DATA6 DATA7 DATA8 (MSB)	PC/VCP PC/VCP PC/VCP PC/VCP PC/VCP PC/VCP PC/VCP PC/VCP	High: data 1 Low: data 0 Information will be expressed for parallel data of every signal from bit No.1 to No.8.
10	28	PeriphClk	PC/VCP	Reverse data transfer : Sends "Low" data when HostAck is "Low". Returns to "High" when HostAck becomes "High".
11	29	PeriphAck	PC/VCP	Forward data transfer : High : VCP is on BUSY status. Low : VCP can accept data.
12		AckReverse	PC/VCP	High: Forward data transfer (Receive) Low : Reverse data transfer (Send)
13		Xflag	PC/VCP	High : During supporting ECP mode
14		HostAck	PC/VCP	Reverse data transfer : High : PC is on BUSY status. Low : PC can send data.
16•17		GND		Earth
18		High	PC/VCP	PeripheralLogicHigh
19 - 30		GND	PC/VCP	Earth
31	16	Reverse Request	PC/VCP	Low : When PC requests VCP to send data
32		Periph Request	PC/VCP	Low : When VCP requests PC to send data
15• 33 - 35		NC		Unused
36		1284 Active	PC/VCP	Becomes "High" when VCP requests each mode of IEEE1284.

PRECAUTIONS

FEATURES

CONNECTIONS

PREPARATION

TROUBLE-SHOOTING

OTHERS

CONNECTION WITH SCSI DATA SIGNAL EQUIPMENT

Operation through SCSI data signal is available as you insert the SCSI board (option) to the optional SCSI board slot on the rear panel. For details, see the operation manual of the optional SCSI board.

Make sure to turn off the power before setting.

(EXAMPLE)

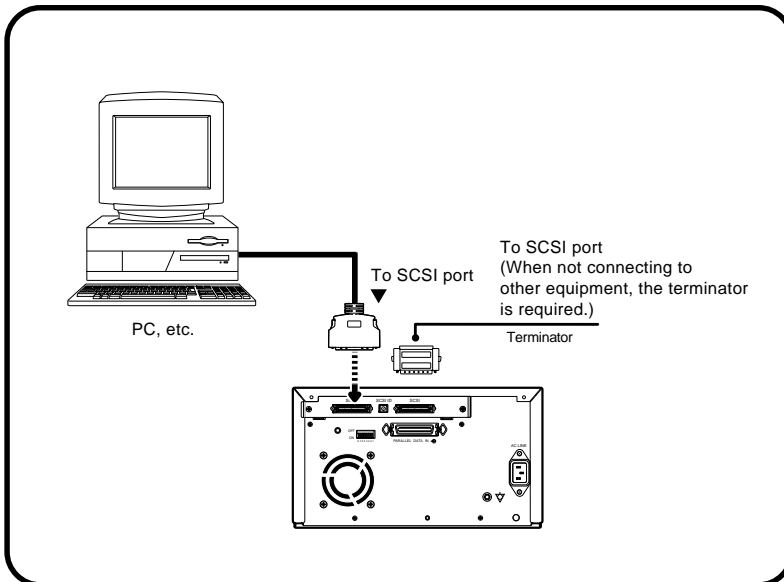

- 1 Connect the unit with PC through SCSI cable.
- 2 Set the slide switch in the printing unit to "OPTION (SCSI)".

■ SETTING SCSI ID SWITCHES

Set the SCSI ID switches (SCSI ID) on the rear panel according to the connected equipment.

- No.7 is provided for personal computer you use and No. 0 for built-in hard disk (of Macintosh).
- When another SCSI data signal equipment is connected to the personal computer, make sure not to duplicate the ID number with this unit.
- Select the SCSI ID number to between 1 and 6 (for Macintosh) or 0 and 6 (for Windows®95/98).

NOTE

When this unit is not connected to other equipment except the host computer, terminate the port with the terminator supplied with this unit.

BEFORE OPERATION

Before printing,

1. Remove the transport screw on the bottom of printing mechanism and the protective cushion.
(See below)
2. Install the print paper and ink cassette. (pages 15-17)

PAPER SHEET SET AND INK SHEET

When using this unit for printing, make sure to use the following types of paper sheet and ink sheet set. Refer to page 27 "OPTION".

REMOVING TRANSPORT SCREW AND PROTECTIVE CUSHION

To prevent damage during transportation/shipping, a protective cushion is inserted into the mechanism, and the printing mechanism is locked into position from the bottom with a transport screw.

Remove the screw by the following procedures before using this unit.

REMOVING THE TRANSPORT SCREW ON THE BOTTOM OF PRINTING MECHANISM

- 1 Turn the printer carefully onto one side and remove the transport locking screw with a coin or screwdriver.
- 2 Attach the transport screw to the storage location on the rear panel of the printer.

The transport screw and protective cushion must always be used during shipping or transport to avoid damage.

REMOVING THE PROTECTIVE CUSHION

Unplug the power cord from outlet for safety.

- 1 Press OPEN button.

The printing unit advances to the front.

NOTE

Do not touch the thermal head.
Fingerprints or dust on the thermal head will degrade the print quality.

- 2 Remove the protective cushion from the right side of the unit.

Save the protective cushion for transporting the unit.

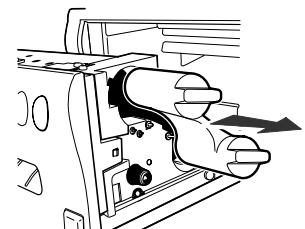
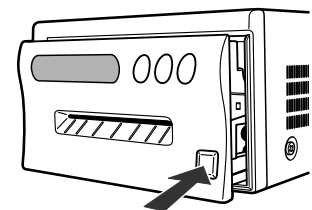
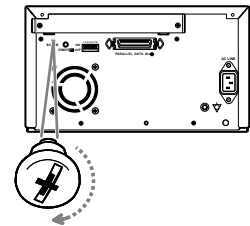
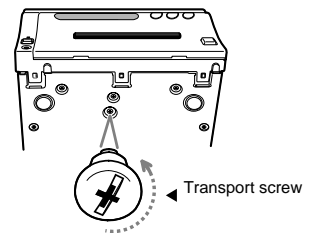

PRECAUTIONS

FEATURES

CONNECTIONS

PREPARATION

TROUBLE-SHOOTING

OTHERS

BEFORE OPERATION

INSTALLATION OF PRINT PAPER

For using thermal paper, set the paper by the following steps.

- 1 Put the supplied attachments on the both sides of the thermal paper roll.**

NOTE

Set the attachments as shown in the right figure. Make sure to put the attachment on the correct position.

- 2 Unroll the thermal paper about 20cm (8 inch) and cut it not to use sticky part.**

Remove the sticky part, dust, or fingerprints on the paper.

- 3 Cut the both edges of the paper.**

The thermal paper setting is completed.

NOTE

Sheet cartridge error appears when an ink sheet is installed though the printer driver selects thermal paper.
The error appears during data transfer and start of printing operation.

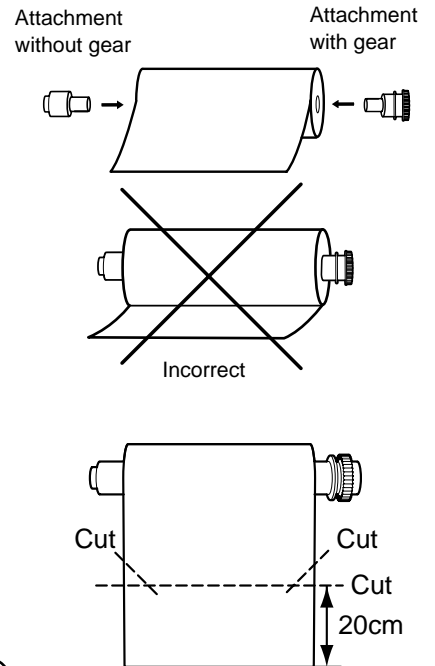

■ INSTALLING PRINT PAPER

- 1 Move the paper release lever toward the front of the printer as shown by the arrow.**

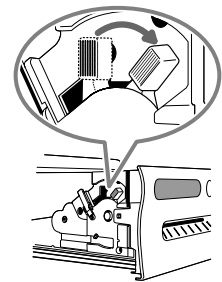

- 2 Insert the print paper in the position as shown right.**

Place the gear to the right side.

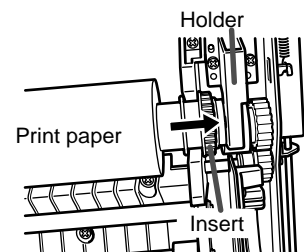

To set the left side, press the holder in the unit to the left and insert the print paper roller.

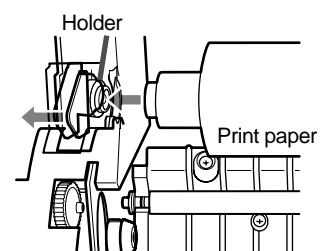

3 Insert the print paper under Roller ① and ② in order.

4 Insert the edge of the print paper under Roller ③.

Be sure to insert the paper straight.

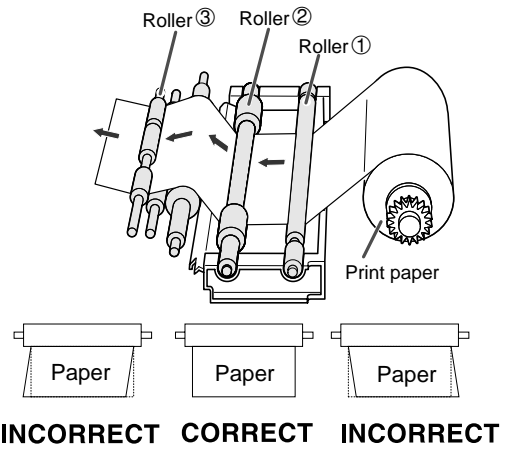

5 Feed the print paper through the paper outlet with your hand.

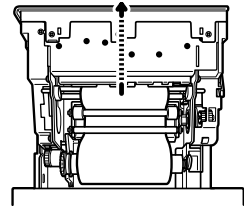

6 Pull the print paper to eliminate slack.

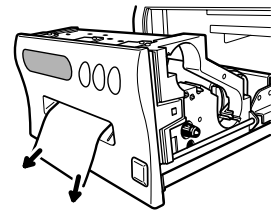

7 Move the knob on the side of the printing unit to the direction as indicated by the arrow.

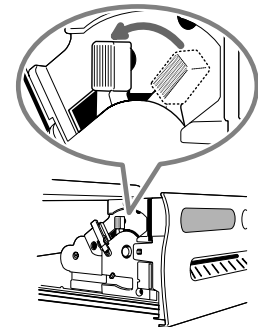

NOTE

If too much paper is fed, ALARM lamp may light. In this case, press PAPER FEED & CUT button.

INSTALLATION OF INK SHEET (For color print)

NOTE

When using thermal paper, do not install the ink sheet.

■ INSTALLING THE INK SHEET

Load the ink cassette with the ink sheet rolls before inserting the ink cassette into the unit.

1 Put the colored roller of the ink sheet to the ink cassette. (A)(B)

2 Put the thin stick of white roller to the ink cassette. (C)

3 Put the thick stick of white roller to the ink cassette. (D)(E)

On the (D) position, turn the roller and set the notch of the roller side to the hole of the cassette.

The roller can be installed when the notch is put through the hole.

■ INSTALLING THE INK CASSETTE

1 Eliminate any slack of the ink sheet.

Hold the colored roller and turn the white roller.

2 Insert the ink cassette with the ink sheet into its compartment.

Insert the ink cassette with the knob side toward you until it is locked into place. When taking the ink cassette out of the compartment, press the ink cassette locking holder to release the lock. Refer to page 8.

■ INSERT THE PRINTING UNIT

1 Push the printing unit until it is locked into place.

2 After plugging the power cord, press POWER button on the front panel.

3 Press ON LINE button to turn off the ON LINE lamp.

4 Press PAPER FEED & CUT button.

The print paper is automatically cut after feeding about 10 cm (4 inches).

5 Repeat the above step **4** once or twice.

Fingerprints and dust can be removed by feeding the print paper. The printing unit is initialized.

3 Press ON LINE button to turn on the ON LINE lamp.

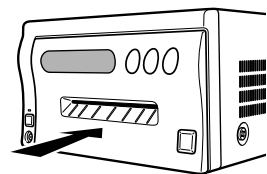
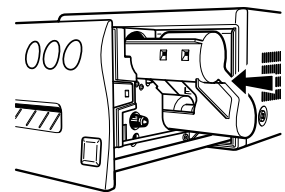
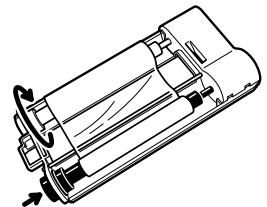
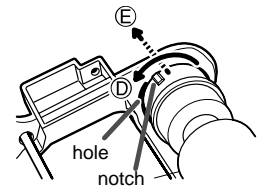
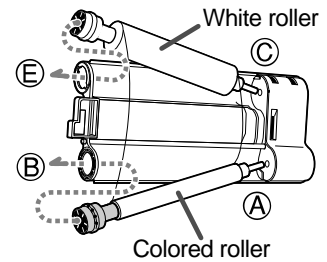

NOTE

- Do not feed the print paper more than 2 times. Doing so will not allow the number of prints indicated on page 27 to be printed.

The installation of print paper and ink cassette is completed.

USAGE AND KEEPING OF PAPER SHEET SET

■ BEFORE PRINTING

- Fingerprints or dust on the paper's surface may degrade print quality and cause paper jams. Immediately after the paper is replaced, 2-3 images may be printed with a blank part due to hand's dust or oil. Refer to Pages 16 - 17.
- When print paper is rapidly transferred from a cool place to a hot place, vapor or dew will be generated on the paper's surface causing paper jams or degraded print quality. Leave the print paper in the room to stabilize its temperature before using it.
- When print paper and ink sheet run out during printing, the printing operation stops and the error messages such as "PAPER EMPTY" and "SHEET/PAPER" lamp on the monitor and LCD display are lit. Set new ink sheet or print paper.
- If paper feeding is repeated while installing the print paper, the indicated number of prints may not be done.

■ AFTER PRINTING

- When the printed paper is touched by a wet hand, the print may be discolored.
- Fading may occur if the print-face is exposed to organic chemical agents which may affect print paper (e.g. alcohol, ester, ketone based).
- Fading will be accelerated upon contact with PVC-based materials (e.g. adhesive tapes, rubber erasers, etc.).
- Avoid storing prints in direct sunlight or places with high humidity.
- Leaving the print paper in contact with PVC-based materials causes color of print paper to come off and to be stained.

■ STORAGE

- Never store print paper in places that are close to heater, hot (5°C-40°C(41°F-104°F)) , or humid (20-80%RH).

NOTE

If the print paper is installed for two or more days, the prints may be rolled after printing. There is no cause for alarm because the print paper is rolled on the inside of the printing unit.

PRECAUTIONS

FEATURES

CONNECTIONS

PREPARATION

TROUBLE-SHOOTING

OTHERS

INSTALLING PRINTER DRIVER

Printer driver is required to print the data from a personal computer connected with this unit.

The printer drivers for Macintosh and Windows are supplied with this unit.

Product name	Operating conditions
For Windows®	Applies for Microsoft®Windows®95 and Windows®98
For Macintosh™	Applies for Macintosh System 7.5 to 8.5.1

Refer to the operation manual of the driver software or “Read me” for installing.

Macintosh is a trademark of Apple Computer Inc.

Windows®95 and Windows®98 are the registered trademarks of Microsoft Corporation in the U.S.A. and other countries.

TROUBLESHOOTING

INDICATION ON THE FRONT PANEL & COUNTERMEASURES

If for some reason printing is not possible or error occurs during printing, the indicator on the front panel will be lit. In this case, follow the procedure described below.

○ : lit ◐ : goes on and off ● : not lit

ALARM	SHEET/PAPER	OPTION	DATA	Causes and countermeasures	Page
●	○	●	●	The printing unit is not inserted correctly. • Insert the printing unit until it is locked. The sheet cartridge is not installed. *Note : 1 • Install the sheet cartridge. Paper is not set. Paper is not set correctly. • Set the print paper correctly. Paper or ink sheet runs out during printing. *Note : 2 • Install the sheet cartridge.	18 18 16-17 18
◐	●	●	●	The temperature of the thermal head becomes too high. • Wait until the message goes off. *Note : 3	
○	●	●	●	Paper jamming occurs. Other defects. • Refer to "Overcoming paper jams". • Make sure the ON LINE lamp is not lit, and press PAPER FEED & CUT button. If the status is not improved by carrying out this measure, consult your dealer. *Note : 4	22

- *Note : 1 The lamp goes on and off after transferring data and just before starting printing operation.
 *Note : 2 In case of L-size printing, the image is not printed completely.
 *Note : 3 When setting the continuous printing, the continuous printing is carried out after the error message goes off.
 *Note : 4 When the printing unit is pulled out, PAPER FEED & CUT button is invalid.
 After pushing the printing unit until it is locked into place, press the PAPER FEED & CUT button.

PRECAUTIONS

FEATURES

CONNECTIONS

PREPARATION

TROUBLE-SHOOTING

OTHERS

OVERCOMING PAPER JAMS

1 Press OPEN button to pull out the printing unit.

When it is not working, turn off the power once. Then try to press OPEN button again.

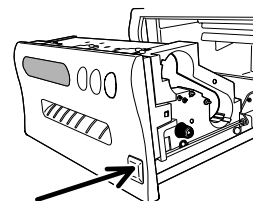

2 Remove the ink cassette.

Unlock the ink cassette by pushing the cassette locking lever to inside.
(Refer to Page 8.)

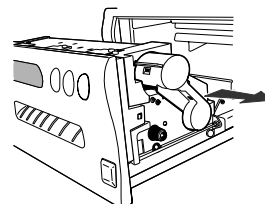

3 Turn the knob on the right side of the printing unit clockwise.

Roll up the print paper completely.

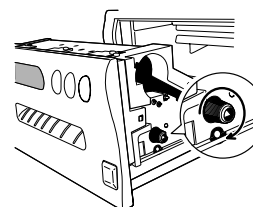

4 Remove the print paper.

5 Cut the defective part of the print paper with scissors.

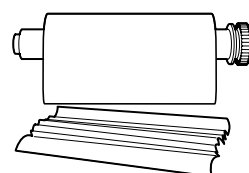

6 Cut both edges of the print paper.



7 Install the print paper. (Refer to pages 16-17.)

BEFORE CALLING FOR SERVICE

■ Use the following troubleshooting chart to try to resolve any apparent defect in operation.

Symptom	Check and Remedy
No power	<p>Is the power cord plug disconnected from the outlet? →Connect the power cord plug to the outlet firmly. →In case of still working the protective circuit, after turning the power off, wait for approx. 2 minutes. Then turn on the power.</p>
The image is not printed.	<p>Is the image data sent to this unit? →Confirm that the image data is sent to this unit. Is the print paper or ink sheet used up? →Check the status. Is the printing unit set correctly? →Set the printing unit correctly.</p>
The stored image in the memory cannot be enlarged to fill the maximum print area.	<p>Is the appropriate image data transferred? Is the S size image printed on L size paper?</p>
The image can not be transferred.	<p>Is the ON LINE lamp lit? →Press the ON LINE button. Is the slide switch in the printing unit set correctly? →Set the slide switch correctly.</p>
COPY button does not work.	<p>Is the image transferred? Is the ON LINE lamp lit? →Turn off the ON LINE lamp.</p>
The host coputer does not recognize this unit.	<p>Is the SCSI ID switch setting duplicated with another device setting? →Check the SCSI ID switch setting.</p>

PRECAUTIONS

FEATURES

CONNECTIONS

PREPARATION

TROUBLE-
SHOOTING

OTHERS

CLEANING

Cleaning as the following shows helps the stable use of this unit for a longer term.

Preparations

Alcohol (isopropyl alcohol)

Tissue paper (Fold in half about 4 times, and use the folded side to clean.)

Cotton buds

Cleaning kit (Option)

Other : Cleaner pen (Option)

Please ask the dealer about options.

Make sure to turn off the power before cleaning.

1 Press OPEN button to pull the printing unit out.

2 Remove the ink cassette and print paper.

3 Wipe the ink sheet sensor.

Clean the parts which the arrows show.

Wipe dust with cotton buds etc. which is soaked in a small amount of alcohol.

4 Wipe the ink sheet sensor reflection plate.

Clean the metal reflection plate.

Wipe with tissue paper etc. which is soaked in a small amount of alcohol carefully.

NOTE

Reflection plate transport screw is fixed with bonding agent. Do not wipe this bonding agent.

5 Wipe the head.

Cleaning the part under the thermal head which develops heat.

Wipe the head cleaning part carefully with tissue paper etc. which is soaked in a small amount of alcohol.

NOTE

- Do not damage the thermal head.
- When the symptom of the poor print quality is not corrected even if the head is cleaned, replacing the thermal head is required. Contact your dealer.
- Thermal head is hot right after printing. Wait until the head temperature is low when cleaning the thermal head.

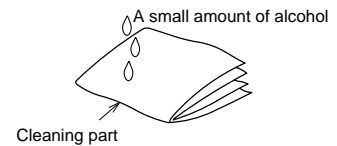

How to fold tissue paper



Cleaning kit (Option)

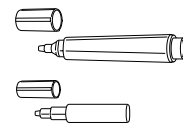

Cleaner pen

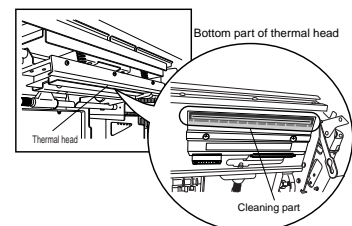
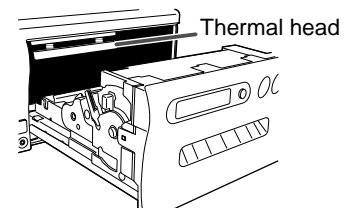
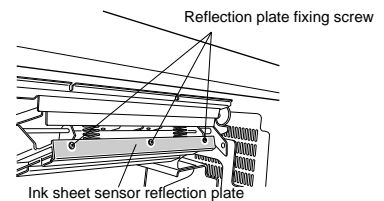
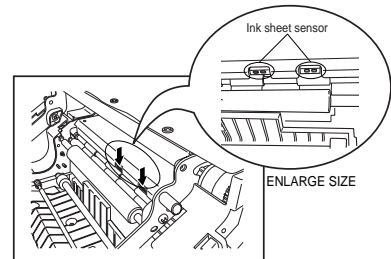

Clean this unit as following steps every 10 rolls of sheet.
Make sure to turn off the power first.

1 Cleaning paper guide shaft.

The seal paste is stuck on the ditch part of the shaft if you use it for a long time.
Wipe with tissue paper etc. which is soaked in a small amount of alcohol carefully.

NOTE

The black surface is coated with Teflon. Do not touch it with metals.

2 Cleaning paper end sensor.

Wipe the dust with cotton buds which is soaked in a small amount of alcohol.

3 Cleaning rubber roller.

The seal paste and dust etc. are stuck on the rubber roller if you use it for a long time.
Wipe with tissue paper etc. which is soaked in a small amount of alcohol carefully.

4 Cleaning print outlet.

The seal paste may be stuck on the paper guide inside or dust may comes from the print outlet.
Use the optional cleaning kit to clean inside as the picture shows.

NOTE

Do not use alcohol etc. when cleaning the print outlet.

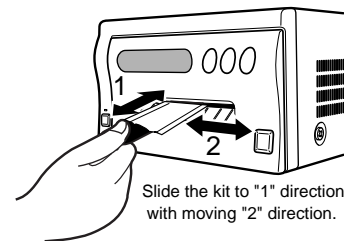
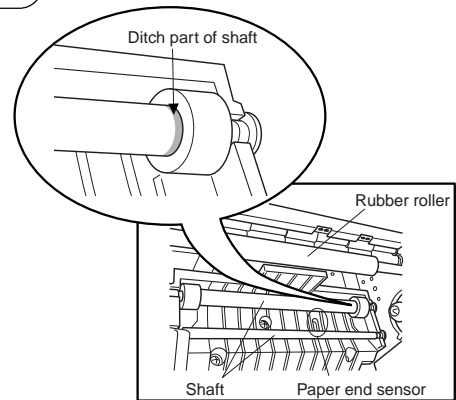

Slide the kit to "1" direction with moving "2" direction.

SPEC & OPTIONS

SPECIFICATIONS

Class	Digital Colour Printer		
Model	CP770DW		
Printing method	Sublimation Dye Thermal 3 color faces progressive printing (yellow, magenta and cyan)		
Print quality	Dot resolution	Max. 1,344x 960pixels (S size)	
	325PPI	Max. 1,676x 1,344pixels (L size) PPI : Pixel Per Inch	
Number of grades	256 (8 bits) for each color (About 16.7 million colors)		
Printing time	S/S-wide size	Approx. 19 sec./sheet (No surface coated)	
	L/L-wide size	Approx. 27 sec./sheet (No surface coated)	
	(The printing time chages depending on the Mode)		
Ink sheet	Special cartridge method		
Print paper	<u>Special roll paper</u>	<u>L size 162 x 110mm</u>	
	Printing area	L-wide mode	130 x 104.8mm
		L mode	130 x 99.8mm
	<u>Special roll paper</u>	<u>S size 110 x 107mm</u>	
	Printing area	S-wide mode	104.8 x 75mm
		S mode	99.8 x 75mm
Supply method	Automatic		
Input/Output terminal	Parallel data interface (36 pin)		
Power supply	AC 120V, 50/60Hz, AC 220-240V 50/60Hz		
Power consumption	1.3A (AC120V, 50/60Hz) during printing (0.2A when not printing) 0.7A (AC220-240V, 50/60Hz) during printing (0.1A when not printing)		
Installation conditions	Temperature :	5°C - 40°C (41°F - 104°F)	Humidity : 20 - 80% (No dewing)
Operation altitude	Within Horizontal ±5°		
Outside dimensions	280(W) x 150(H) x 398(D) mm		
Weight	13.1kg		
Accessories	Power cord (1), Ink cassette (1), Operation manual (1), Spacer (4), Sheet "Installing print paper and ink sheet" (1) , Printer driver (2 floppy disks), Attachments for thermal paper (1 set)		

OPTIONS

■ INK SHEET

Product name	Ink sheet size	No. of prints	Usage
PK700S	S size	200	For 3 color use
PK700L	L size	130	For 3 color use

■ PRINT PAPER

Product name	Ink sheet size	No. of prints	Usage
CK700	S/L size	S size : 200 L size : 130	For 3 color use
CK710FCS			
K65H	S/L size	S size : 200 L size : 125	For thermal printing
K65HM	S/L size	S size : 200 L size : 125	For thermal printing

■ PRINT PAPER AND INK SHEET

Product name	Ink sheet size	No. of prints	Usage
CK700S4P	S size	110	For surface-laminated color print
CK700L4P	L size	75	For surface-laminated color print
CK700SC	S size	200	For 3 color use (sticker)
CK700LC	L size	130	For 3 color use (sticker)
CK710SPC	S size	200	For 3 color use (16-division pre-cut sticker)
CK710LPC	L size	130	For 3 color use (16-division pre-cut sticker)
CK714SPC	S size	200	For 3 color use (4-division pre-cut sticker)
CK7V1SPC	S size	200	For 3 color use (10-division irregular pre-cut sticker)
CK700S4P(HX)	S size	110	For surface-laminated color print (ID photo)
CK700L4P(HX)	L size	75	For surface-laminated color print (ID photo)

For CK7V1SPC, refer to the optional catalog.

■ INK CASSETTE AND INK SHEET

Product name	Ink sheet size	No. of prints	Usage
PKC700S	S size	200	For 3 color use
PKC700L	L size	130	For 3 color use

PRECAUTIONS

FEATURES

CONNECTIONS

PREPARATION

TROUBLE-
SHOOTING

OTHERS

Mitsubishi Electric Europe B.V.

UK Branch

Travellers Lane, Hatfield, Herts. AL10 8XB, England, U.K.
Phone (1) 707 276100 FAX (1) 707 278755

German Branch

Gothaer Strasse 8, Postfach 1548, 40880 Ratingen 1, Germany
Phone (2102) 4860 FAX (2102) 486-732

French Branch

25, Boulevard des Bouvets - 92741 NANTERRE cedex
Phone (01) 55.68.55.00 FAX (01) 55.68.57.31

Italian Branch

Centro Direzionale Colleoni, Palazzo Perseo-Ingresso 2,
Via Paracelso 12, 20041 Agrate Brianza, (Milano) Italy
Phone (039) 60531 FAX (039) 6057694

Benelux Branch

Nijverheidweg 23 A. 3641 RP. Postbus 222, 3640 AE Mijdrecht
Phone 02972-82461 FAX 02972-83936

Spanish Branch (Barcelona)

Sucursal en españa
Polígono Industrial "Can Magí", Calle Joan Bucallà 2-4,
Apartado de Correos 420, 08190 Sant Cugat del Vallès,
Barcelona, Spain
Phone (3) 589-3900 FAX (3) 589-4448

Manufactured by Mitsubishi Electric Corporation
1 Zusho Baba, Nagaokakyo-City, Kyoto Japan